

XT Series 10 and 12 Foot Extra Heavy Duty Rectangular Tables with Lumber Top and Seats



Model XT/G-10UP 10 Ft. Extra Heavy Duty Portable Rectangular Table with Hot Dip Galvanized Frames and Untreated Southern Yellow Pine Top and Seats

- **Constructed specifically for heavy use areas**
- **Nontip, nontrip walk-through design**
- **All welded end frames are fabricated from 2-3/8" diameter steel pipe**
- **Die-formed center channel and diagonal braces align and strengthen entire table**
- **Frames are hot dip galvanized after fabrication for superior corrosion resistance**
- **Precision drilled, Untreated #1 Southern Yellow Pine top and seat planks**
- **Limited lifetime warranty on frames**

SPECIFICATIONS:

- **XT Series** end frames shall be one-piece welded construction, fabricated from 2.375" (2-3/8") O.D. steel pipe to meet 2" nominal steel pipe size specifications with 2" x 2" x 3/16" A-36 structural grade steel angle for attaching the seats and tops.
- Table frame design shall incorporate nontip, nontrip, walk-through design features. Bends shall be tightly formed to prevent tipping when weight is on one side.
- **Model XT/G-10UP** shall be a nominal 10 ft. long with three frames.
- **Model XT/G-12UP** shall be a nominal 12 ft. long with three frames.
- Nominal table height shall be 30". Nominal seat height shall be 18".
- Frames shall be supported by diagonal braces of 1-5/16" O.D. x 14 ga. wall steel pipe that shall connect to the underside of the table top.
- **Standard:** All frame components shall be hot-dip galvanized after fabrication to ASTM-A123 to maintain an average zinc coating of 2.0 oz. per sq. ft. of surface area (indicated by "/G" in model no.), e.g. XT/G-10UP.
- All galvanized fasteners shall be provided for assembly.
- **Standard:** Lumber shall be Untreated #1 grade Southern Yellow Pine (indicated by "UP" in model no., e.g. XT/G-10UP) 2" x 10" nominal sized planks, kiln dried to reduce moisture content. All lumber shall be precision drilled to facilitate assembly and shall have all exposed edges removed to a 3/8" radius.
- **Optional:** Color choices of powder coated steel frame components. For optional colors choices see Specification Bulletin # SPC-CO-001.
- **Optional:** Treated #1 Southern Yellow Pine is readily available and shall be pressure treated (KDAT) to preserve wood against decay. To specify, change "UP" in model no. to "TP", e.g. UT/G-6TP. (Cedar, Fir and Redwood are available when in stock -please inquire.)

AVAILABLE OPTIONS

10' or 12' length

Choice of colors of Powder Coated finish for steel frame components

Pressure treated #1 Southern Yellow Pine lumber (Cedar, Fir, or Redwood lumber when in stock)

RJThomas Mfg. Co., Inc.

PO Box 946 • Cherokee, IA 51012-0946 • PH: 712-225-5115 • 800-762-5002 • FAX: 712-225-5796
E-mail: pilotrock@rjthomas.com • Web Site: <http://www.pilotrock.com>

© 2008 RJThomas Mfg. Co., Inc. PILOT ROCK® Park Products is a registered trademark of RJThomas Mfg. Co., Inc.

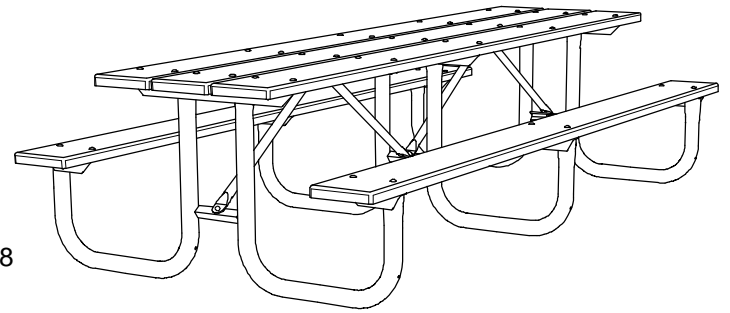
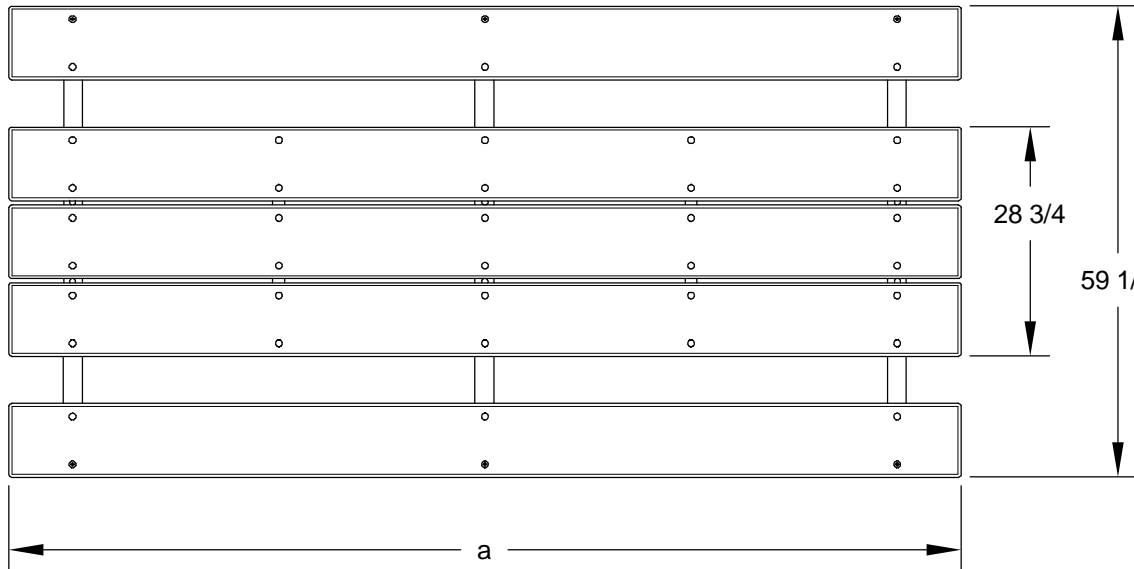

MODEL NUMBER	DIMENSION	
	a	b
XT/G-10	119-1/2	51-3/4
XT/G-12	143-1/2	70

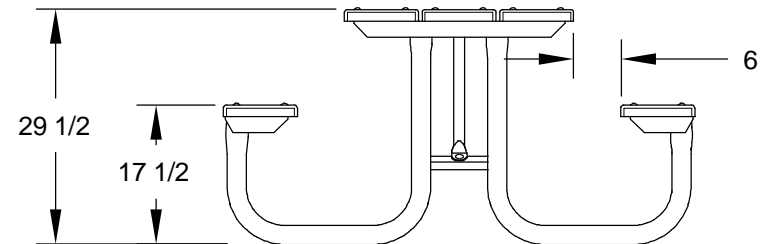
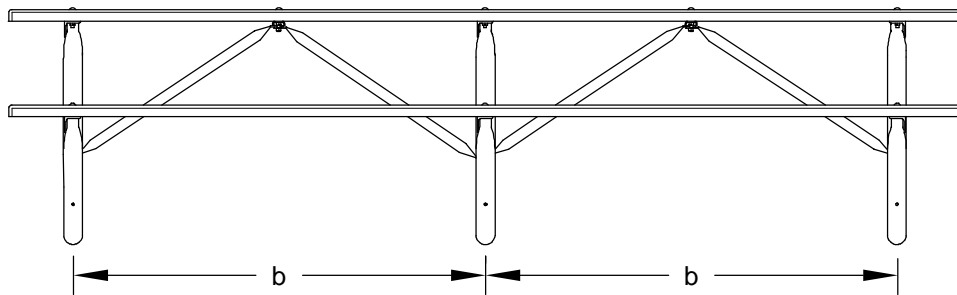

R.J. **THOMAS MFG. Co., INC.**
P.O. Box 946 • Cherokee, IA 51012

DRAWN BY
WWM

TITLE XT SERIES EXTRA HEAVY DUTY 10 AND 12 FOOT PORTABLE RECTANGULAR TABLE
WITH LUMBER TOP AND SEATS

DATE 4-30-08

DWG. NO. AI-1849