

XT Series 10 and 12 Foot Extra Heavy Duty Rectangular Tables with Aluminum Top and Seats



Model XT/CR-10AL 10 Ft. Extra Heavy Duty Portable Rectangular Table with Red Powder Coated Frames and Clear Anodized Aluminum Top and Seats

- **Constructed specifically for heavy use areas**
- **Nontip, nontrip walk-through design**
- **All welded end frames are fabricated from 2-3/8" diameter steel pipe**
- **Die-formed center channel and diagonal braces align and strengthen entire table**
- **Frames are hot dip galvanized after fabrication for superior corrosion resistance**
- **Seats and Top are Aluminum with a clear anodized maintenance free finish**
- **Limited lifetime warranty on frames**

AVAILABLE OPTIONS

10' or 12' length

Choice of colors of Powder Coated finish for steel frame components

Powder Coat Finish in choice of colors for aluminum top and seat components

SPECIFICATIONS:

- **XT Series** end frames shall be one-piece welded construction, fabricated from 2.375" (2-3/8") O.D. steel pipe to meet 2" nominal steel pipe size specifications with 2" x 2" x 3/16" A-36 structural grade steel angle for attaching the seats and tops.
- Table frame design shall incorporate nontip, nontrip, walk-through design features. Bends shall be tightly formed to prevent tipping when weight is on one side.
- **Model XT/G-10AL** shall be a nominal 10 ft. long with three frames.
- **Model XT/G-12AL** shall be a nominal 12 ft. long with three frames.
- Nominal table height shall be 30". Nominal seat height shall be 18".
- Frames shall be supported by diagonal braces of 1-5/16" O.D. x 14 ga. wall steel pipe that shall connect to the underside of the table top.
- **Standard:** All frame components shall be hot-dip galvanized after fabrication to ASTM-A123 to maintain an average zinc coating of 2.0 oz. per sq. ft. of surface area (indicated by "/G" in model no.), e.g. XT/G-10AL.
- All galvanized fasteners shall be provided for assembly.
- Aluminum shall be extruded 6063-T6 aluminum alloy in planks with dimensions equivalent to that of 2" x 10" nominal sized lumber. The plank design shall be 1-3/4" x 9-5/8" with four structural reinforcement ribs for greater rigidity. Aluminum planks shall be provided with a clear anodized finish as per anodizing specification 204 R1. Aluminum clips to fasten planks to frames are included.
- Channel end caps shall be of extruded 6063-T6 aluminum alloy provided with a clear anodized finish as per anodizing specification 204 R1. End caps shall be press fitted over ends of aluminum planks and mechanically fastened in place at the factory.
- Table tops are assembled into single units (at the factory) with one-piece end caps across each end.
- **Optional:** Color choices of powder coated steel frame components. For optional colors choices see Specification Bulletin # SPC-CO-001.
- **Optional:** Aluminum top and seat planks and end caps shall have powder coat finish. For color choices see Specification Bulletin # SPC-CO-001.

RJThomas Mfg. Co., Inc.

PO Box 946 • Cherokee, IA 51012-0946 • PH: 712-225-5115 • 800-762-5002 • FAX: 712-225-5796
E-mail: pilotrock@rjthomas.com • Web Site: <http://www.pilotrock.com>

© 2008 RJThomas Mfg. Co., Inc. PILOT ROCK® Park Products is a registered trademark of RJThomas Mfg. Co., Inc.

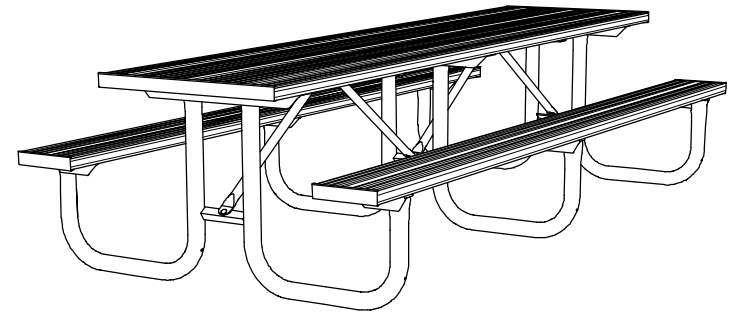
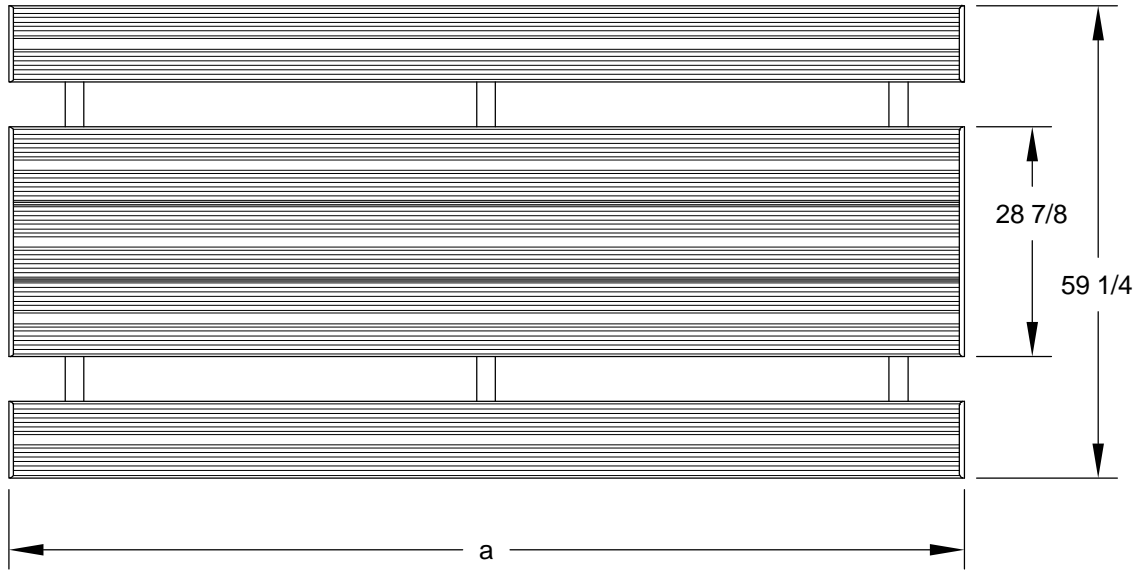

MODEL NUMBER	DIMENSION	
	a	b
XT/G-10	120	51-3/4
XT/G-12	144	70

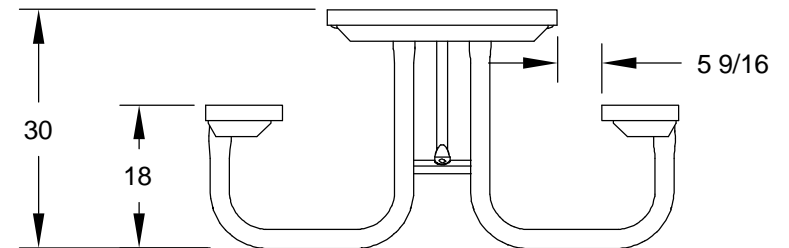
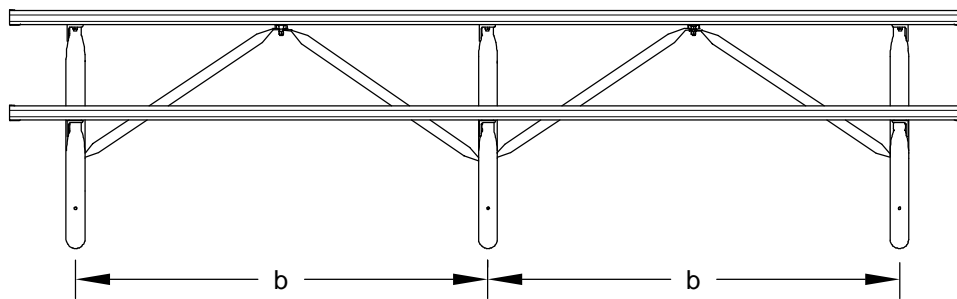

R.J. **THOMAS MFG. Co., INC.**
P.O. Box 946 • Cherokee, IA 51012

DRAWN BY
WWM

TITLE **XT SERIES EXTRA HEAVY DUTY 10 AND 12 FOOT PORTABLE RECTANGULAR TABLE WITH ALUMINUM TOP AND SEATS**

DATE **4-30-08**

DWG. NO. **AI-1850**