

Grey Creek Series, Model B30 3, 4, and 6 Ft. Surface Mount Bench with Lumber Timbers



*Model B30/CB-6IB34 6 Ft. Surface Mount Bench
with Black Powder Coat Frames
and Indonesian Balau Wood 3" x 4" Timbers.*

- **Comfortable seat design may be accessed from either side**
- **Design offers extensions to make longer benches with additional armrests**
- **Wide, comfortable armrest loops integrated into end frames**
- **Sturdy, formed and welded steel frame construction**
- **Powder Coat or Hot Dip Galvanized frame finish**
- **Precision drilled Hardwood 3" x 4" Timbers**
- **Quality construction throughout**

AVAILABLE OPTIONS

- **3', 4', or 6' models**
- **Powder Coat Finish in choice of colors or Hot Dip Galvanized steel frame components**
- **Treated #1 Southern Yellow Pine or Construction Heart Redwood lumber**
- **Bench Extensions for 3' and 4' benches**
- **Custom Lettering and Plaques available (call for details)**

SPECIFICATIONS:

- **Model B30** series end frames are one-piece welded construction with 3/8" x 2-1/2" A-36 flat steel bar legs and die-formed foot with 25/32" dia. anchor holes. Seat bracket are constructed of 3/8" x 2-1/2" A-36 flat steel bar with holes to mount four 3" x 4" timbers. The end frames include a welded-on circular armrest formed from 1/4" x 2-1/2" A-36 flat steel bar.
- **Model B30-3** is a nom. 3 ft. in length.
- **Model B30-4** is a nom. 4 ft. in length.
- **Model B30-6** is a nom. 6 ft. in length.
- Benches are designed to be permanently surface mounted using 25/32" dia. holes provided in each frame foot for use with concrete anchors (anchors not included).
- **Standard:** Frames are finished in Black powder coat (indicated by "/CB" in model no., e.g. B30/CB-3IB34).
- **Standard:** Lumber is Indonesian Balau Wood 3" x 4" nominal sized timbers (indicated by "IB" in model no., e.g. B30/CB-3IB34). All timbers are precision drilled for fast, easy assembly and have all exposed edges removed to a 3/8" radius with a bullnose profile timber used on outside positions.
- **Optional:** Frames are hot-dip galvanized after fabrication to ASTM-A123 to maintain an average zinc coating of 2.0 oz. per sq. ft. of surface area. (To specify, change "/CB" in model no. to "/G", e.g. B30/G-3IB34).
- All fasteners are provided for assembly.
- **Optional:** Color choices of powder coated steel frame components. For optional colors choices see Specification Bulletin #SPC-CO-001.
- **Optional:** Lumber is #1 grade Southern Yellow Pine, pressure treated and kiln dried after treatment (KDAT) to preserve wood against decay, or Construction Heart Redwood. (To specify, change "IB" in model no. to "TP" for Treated Pine, e.g. B30/CB-3TP34, or to "CO" for Construction Heart Redwood, e.g. B30/CB-3CO34.)
- Bench extensions of a matching design are available on 3 and 4 ft. bench models. For additional information please refer to Specification Bulletin #SPC-BC-005.

RJThomas Mfg. Co., Inc.

PO Box 946 • Cherokee, IA 51012-0946 • PH: 712-225-5115 • 800-762-5002 • FAX: 712-225-5796
E-mail: pilotrock@rjthomas.com • Web Site: <http://www.pilotrock.com>

© 2008 RJThomas Mfg. Co., Inc. PILOT ROCK® Park Products is a registered trademark of RJThomas Mfg. Co., Inc.

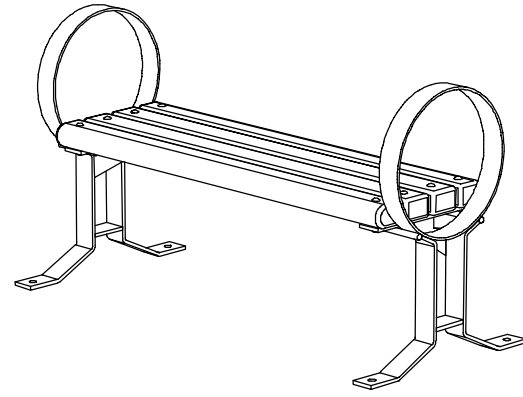
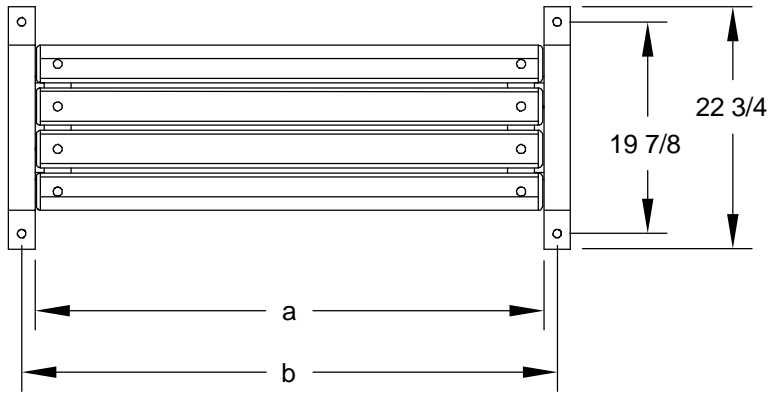

MODEL NUMBER	DIMENSION		
	a	b	c
B30-3	35 3/4	38 1/4	40 3/4
B30-4	47 3/4	50 1/4	52 3/4
B30-6	71 3/4	74 1/4	76 3/4

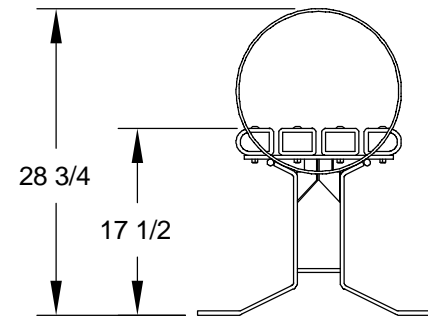
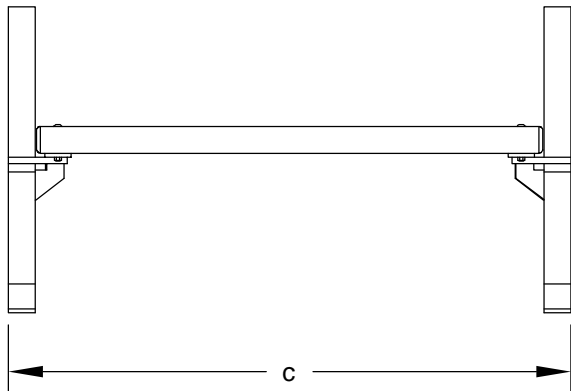

RJThomas Mfg. Co., Inc.
P.O. Box 946 • Cherokee, IA 51012-0946

DRAWN BY
WWM

TITLE **GREY CREEK SERIES MODEL B30 3, 4, AND 6 FOOT FLAT SURFACE MOUNT BENCH WITH 3" x 4" LUMBER TIMBERS**

DATE **8-29-08**

DWG. NO. **AI-1504**