

## Grey Creek Series, Model B31C Embedded Mount 8 Ft. Bench with Lumber Timbers



*Model B31C/G-8IB34 8 Ft. Embedded Mount Bench  
with Hot Dip Galvanized Frames  
and Indonesian Balau Wood 3" x 4" Timbers.*

- **Comfortable seat design may be accessed from either side**
- **Wide, comfortable armrest loops integrated into end frames**
- **Sturdy, formed and welded steel frame construction**
- **Powder Coat or Hot Dip Galvanized frame finish**
- **Precision drilled Hardwood 3" x 4" Timbers**
- **Quality construction throughout**

### **SPECIFICATIONS:**

- **Model B31C Series** end frames are one-piece welded construction with 3/8" x 2-1/2" A-36 flat steel bar legs. Seat brackets are constructed of 3/8" x 2-1/2" A-36 flat steel bar with holes to mount four 3" x 4" timbers. The end frames include a welded-on circular armrest formed from 1/4" x 2-1/2" A-36 flat steel bar.
- **Model B31C-8** is a nom. 8 ft. in length.
- Bench is designed to be permanently anchored by embedding bench legs in concrete footings.
- Bench is provided with a center frame for additional support (indicated by "B31C" in model no., e.g. B31C/CB-8IB34). Center frame does not have armrest.
- **Standard:** Frames are finished in Black powder coat (indicated by "/CB" in model no., e.g. B31C/CB-8IB34).
- **Standard:** Lumber is Indonesian Balau Wood 3" x 4" nominal sized timbers (indicated by "IB" in model no., e.g. B31C/CB-8IB34). All timbers are precision drilled for assembly and have all exposed edges removed to a 3/8" radius with a bullnose profile timber used on outside positions.
- All fasteners are provided for assembly.
- **Optional:** Color choices of powder coated steel frame components. For optional colors choices see Specification Bulletin #SPC-CO-001.
- **Optional:** Frames are hot-dip galvanized after fabrication to ASTM-A123 to maintain an average zinc coating of 2.0 oz. per sq. ft. of surface area. (To specify, change "/CB" in model no. to "/G", e.g. B31C/G-8IB34).
- **Optional:** Lumber is #1 grade Southern Yellow Pine, pressure treated and kiln dried after treatment (KDAT) to preserve wood against decay, or Construction Heart Redwood. (To specify, change "IB" in model no. to "TP" for Treated Pine, e.g. B31C/CB-8TP34, or to "CO" for Construction Heart Redwood, e.g. B31C/CB-8CO34.)

### **AVAILABLE OPTIONS**

**Powder Coat Finish in choice of colors or Hot Dip Galvanized steel frame components**  
**Treated #1 Southern Yellow Pine or Construction Heart Redwood lumber**  
**Custom Lettering and Plaques available (call for details)**

**RJThomas Mfg. Co., Inc.**

PO Box 946 • Cherokee, IA 51012-0946 • PH: 712-225-5115 • 800-762-5002 • FAX: 712-225-5796  
E-mail: pilotrock@rjthomas.com • Web Site: <http://www.pilotrock.com>

© 2008 RJThomas Mfg. Co., Inc. PILOT ROCK® Park Products is a registered trademark of RJThomas Mfg. Co., Inc.

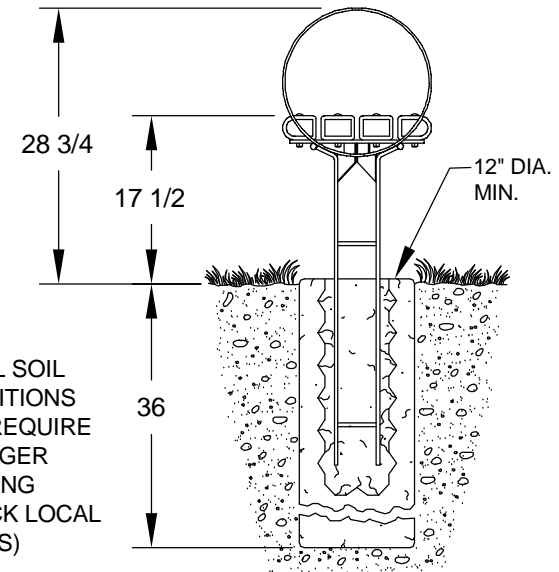
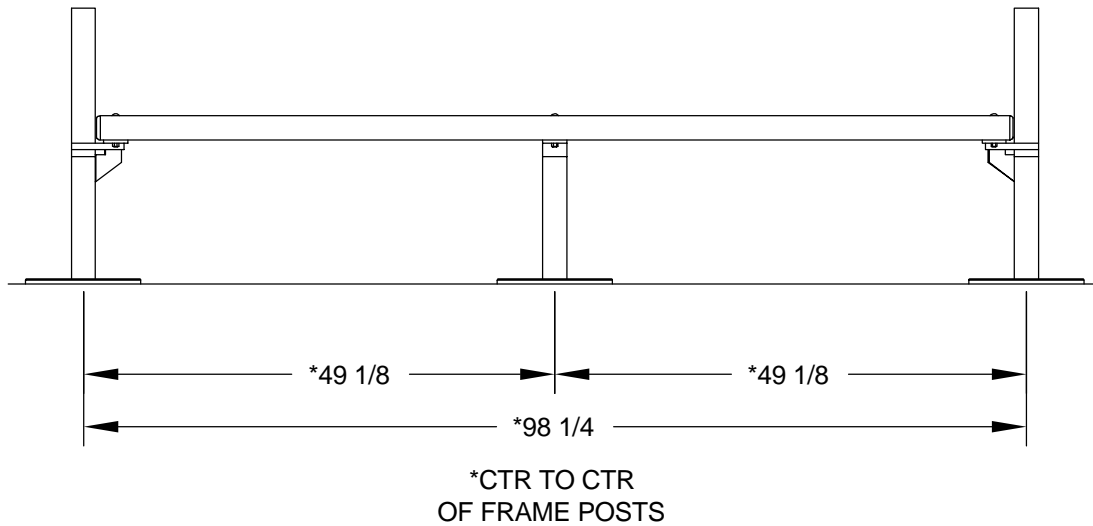
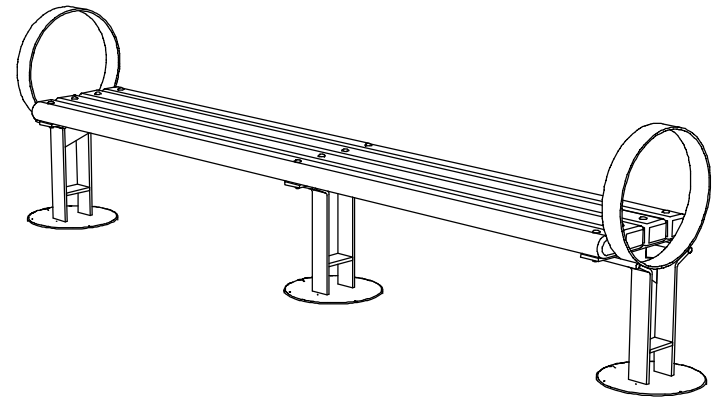
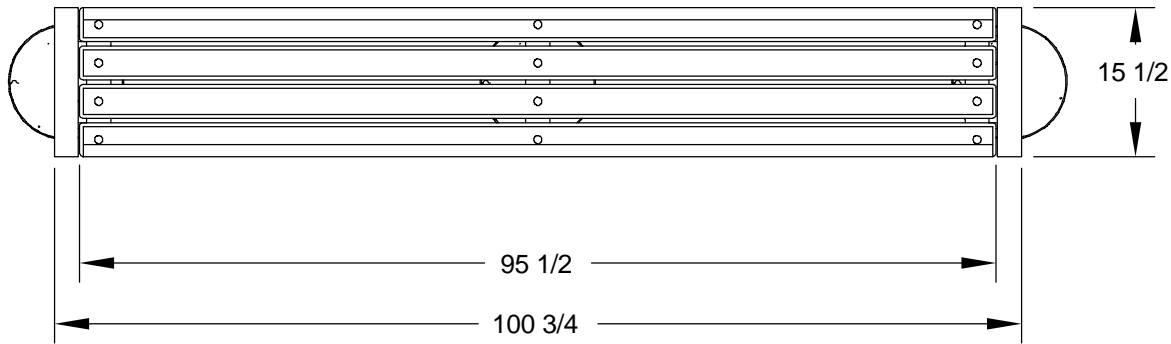

ALL DIMENSIONS IN INCHES

**RJThomas Mfg. Co., Inc.**  
P.O. Box 946 • Cherokee, IA 51012-0946

DRAWN BY  
**WWM**

TITLE **GREY CREEK SERIES MODEL B31C 8 FOOT FLAT EMBEDDED MOUNT BENCH WITH  
3" x 4" LUMBER TIMBERS**

DATE **8-29-08**

DWG. NO. **AI-1569**