



Model BE31/G-4PB34 4 Ft. Embedded Mount Bench Extension with Hot Dip Galvanized Frames and Black Recycled Plastic 3" x 4" Timbers. (Shown with Model B31/G-4PB34 Bench.)

- **Comfortable seat design may be accessed from either side**
- **Designed to join easily with Model B31 benches to make longer benches with additional armrests**
- **Wide, comfortable armrest loops integrated into extension frames**
- **Sturdy, formed and welded steel frame construction**
- **Powder Coat or Hot-Dip Galvanized frame finish**
- **100% Recycled Plastic 3" x 4" Timbers**
- **Quality construction throughout**

SPECIFICATIONS:

- **Model BE31 Series** extension frame is a one-piece welded construction with 3/8" x 2-1/2" A-36 flat steel bar legs. Two seat brackets are constructed of 3/8" x 2-1/2" A-36 flat steel bar with holes to mount four 3" x 4" timbers. The frame shall include a welded-on circular armrest formed from 1/4" x 2-1/2" A-36 flat steel bar.
- Model BE31 bench extension is used with Model B31 3 and 4 ft. benches. Multiple extensions can be added to create any length of bench in 3 and 4 ft. increments. The extension frame replaces one bench end frame which is then moved to the end of the extension. (For information on Model B31 benches refer to Specification Bulletin #SPC-BC-008.)
- **Model BE31-3** is a nom. 3 ft. in length.
- **Model BE31-4** is a nom. 4 ft. in length.
- Bench is designed to be permanently anchored by embedding bench legs in concrete footings.
- **Standard:** Frame is finished in Black powder coat (indicated by "/CB" in model no.).
- **Standard:** Seat is made of 100% Recycled Plastic molded into 3" x 4" nominal sized timbers with solid Cedar color (indicated by "PC" in model no., e.g. BE31/CB-3PC34) formed throughout and a U.V. stabilizer added for ultra-violet protection. All timbers are precision drilled for assembly and all edges have a molded 3/8" radius with a bullnose profile timber used on outside positions.
- All fasteners are provided for assembly.
- **Optional:** Color choices of powder coated steel frame components. For optional colors choices see Specification Bulletin #SPC-CO-001.
- **Optional:** Frame is hot dip galvanized after fabrication to ASTM-A123 to maintain an average zinc coating of 2.0 oz. per sq. ft. of surface area. (To specify, change "/CB" in model no. to "/G", e.g. BE31/G-3PC34).
- **Optional:** Color choices of Recycled Plastic components. For optional colors choices see Specification Bulletin #SPC-CO-001.

AVAILABLE OPTIONS

- **3' or 4' models**
- **Powder Coat Finish in choice of colors or Hot Dip Galvanized steel frame components**
- **Choice of colors of Recycled Plastic**
- **Custom Lettering and Plaques available (call for details)**

RJThomas Mfg. Co., Inc.

PO Box 946 • Cherokee, IA 51012-0946 • PH: 712-225-5115 • 800-762-5002 • FAX: 712-225-5796
E-mail: pilotrock@rjthomas.com • Web Site: <http://www.pilotrock.com>

© 2008 RJThomas Mfg. Co., Inc. PILOT ROCK® Park Products is a registered trademark of RJThomas Mfg. Co., Inc.

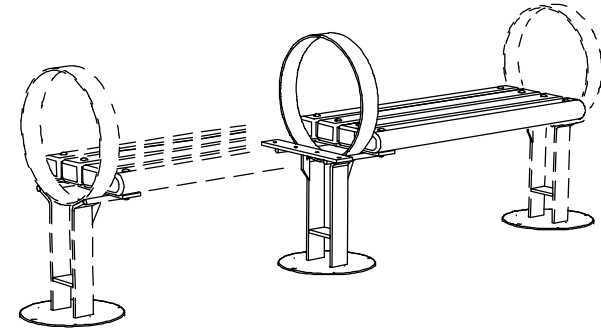
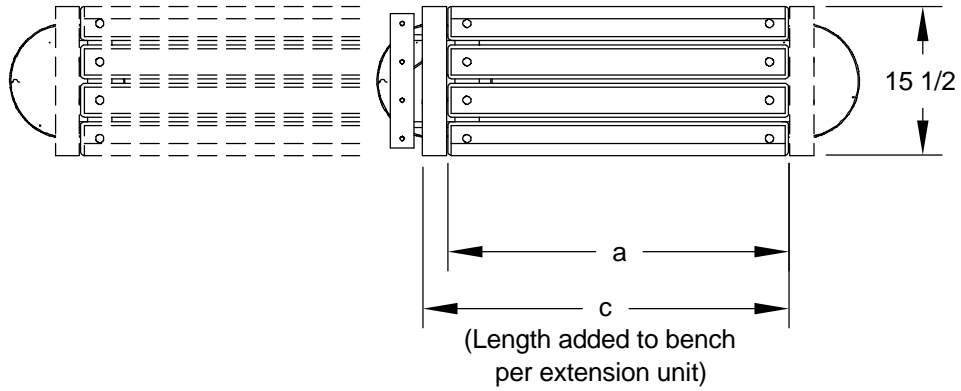

MODEL NUMBER	DIMENSION		
	a	b	c
BE31-3	35 1/2	38 1/4	38 1/4
BE31-4	47 1/2	50 1/4	50 1/4

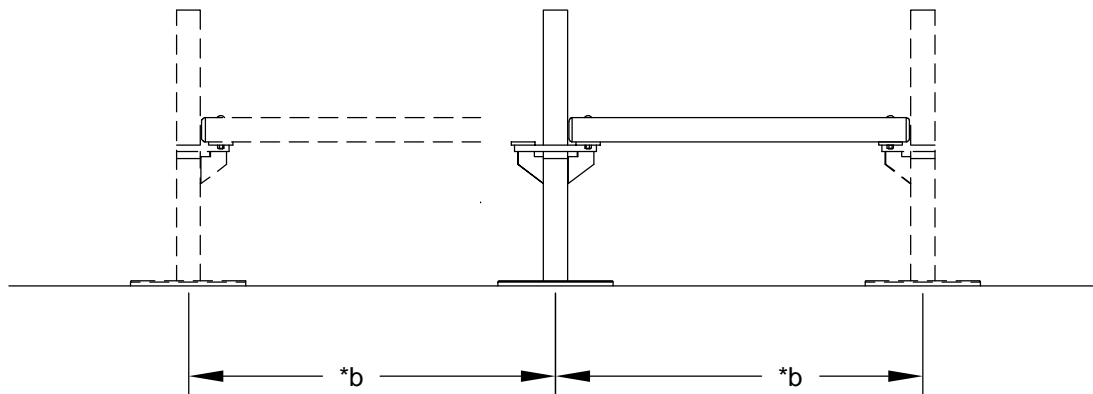

*CTR TO CTR
OF FRAME POSTS

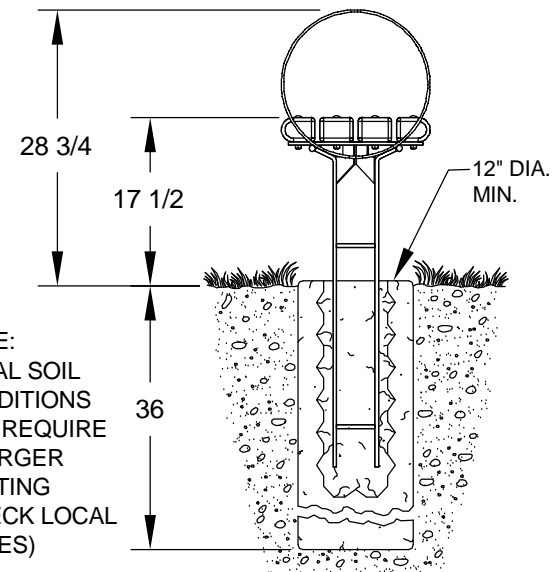

ALL DIMENSIONS IN INCHES

RJThomas Mfg. Co., Inc.
P.O. Box 946 • Cherokee, IA 51012-0946

DRAWN BY
WWM

TITLE GREY CREEK SERIES MODEL BE31 3 AND 4 FOOT FLAT EMBEDDED MOUNT BENCH WITH 3" x 4" RECYCLED PLASTIC TIMBERS (SHOWN WITH GREY CREEK SERIES MODEL B31 BENCH IN PHANTOM)

DATE 8-29-08

DWG. NO. AI-1572