



*Model B32/CB-6IB34 6 Ft. Surface Mount Bench
with Black Powder Coat Frames
and Indonesian Balau Wood 3" x 4" Timbers.*

- **Comfortable contoured full back and seat design**
- **Design offers extensions to make longer benches with additional armrests**
- **Wide, comfortable armrest loops integrated into end frames**
- **Sturdy, formed and welded steel frame construction**
- **Powder Coat or Hot Dip Galvanized frame finish**
- **Precision drilled Hardwood 3" x 4" Timbers**
- **Quality construction throughout**

AVAILABLE OPTIONS

- **3', 4', or 6' models**
- **Powder Coat Finish in choice of colors or Hot Dip steel frame components**
- **Treated #1 Southern Yellow Pine or Construction Heart Redwood lumber**
- **Bench Extensions for 3' and 4' benches**
- **Custom Lettering and Plaques available (call for details)**

SPECIFICATIONS:

- **Model B32 Series** end frames are one-piece welded construction with 3/8" x 2-1/2" A-36 flat steel bar legs and die-formed feet with 25/32" dia. anchor holes. Seat brackets are constructed of 3/8" x 2-1/2" A-36 flat steel bar, die-formed for shape and reinforcement, with holes to mount eight 3" x 4" timbers. The end frames include a welded-on circular armrest formed from 1/4" x 2-1/2" A-36 flat steel bar.
- **Model B32-3** is a nom. 3 ft. in length.
- **Model B32-4** is a nom. 4 ft. in length.
- **Model B32-6** is a nom. 6 ft. in length.
- Bench is designed to be permanently surface mounted using 25/32" dia. holes provided in each frame foot for use with concrete anchors (anchors not included).
- **Standard:** Frames are finished in Black powder coat (indicated by "/CB" in model no., e.g. B32/CB-3IB34).
- **Standard:** Lumber is Indonesian Balau Wood 3" x 4" nominal sized timbers (indicated by "IB" in model no., e.g. B32/CB-3IB34). All timbers are precision drilled for assembly and have all exposed edges removed to a 3/8" radius with a bullnose profile timber used on top and front positions.
- All fasteners are provided for assembly.
- **Optional:** Color choices of powder coated steel frame components. For optional colors choices see Specification Bulletin #SPC-CO-001.
- **Optional:** Frames are hot-dip galvanized after fabrication to ASTM-A123 to maintain an average zinc coating of 2.0 oz. per sq. ft. of surface area. (To specify, change "/CB" in model no. to "/G", e.g. B32/G-3IB34).
- **Optional:** Lumber is #1 grade Southern Yellow Pine, pressure treated and kiln dried after treatment (KDAT) to preserve wood against decay, or Construction Heart Redwood. (To specify, change "IB" in model no. to "TP" for Treated Pine, e.g. B32/CB-3TP34, or to "CO" for Construction Heart Redwood, e.g. B32/CB-3CO34.)
- Bench extensions of a matching design are available on 3 and 4 ft. bench models. For additional information please refer to Specification Bulletin #SPC-BC-017.

RJThomas Mfg. Co., Inc.

PO Box 946 • Cherokee, IA 51012-0946 • PH: 712-225-5115 • 800-762-5002 • FAX: 712-225-5796
E-mail: pilotrock@rjthomas.com • Web Site: <http://www.pilotrock.com>

© 2008 RJThomas Mfg. Co., Inc. PILOT ROCK® Park Products is a registered trademark of RJThomas Mfg. Co., Inc.

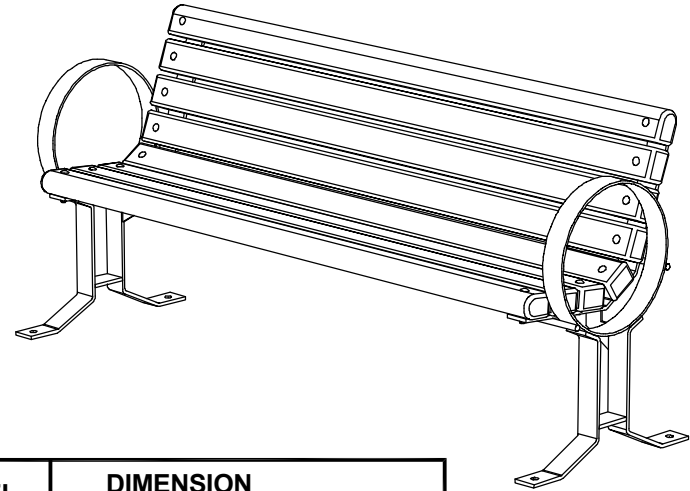
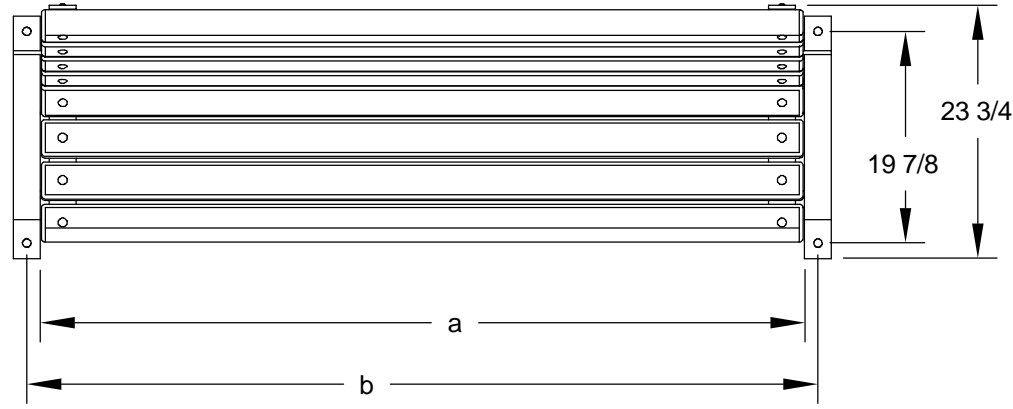

| MODEL NUMBER | DIMENSION | | |
|--------------|-----------|--------|--------|
| | a | b | c |
| B32-3 | 35 1/2 | 38 1/4 | 40 3/4 |
| B32-4 | 47 1/2 | 50 1/4 | 52 3/4 |
| B32-6 | 71 1/2 | 74 1/4 | 76 3/4 |

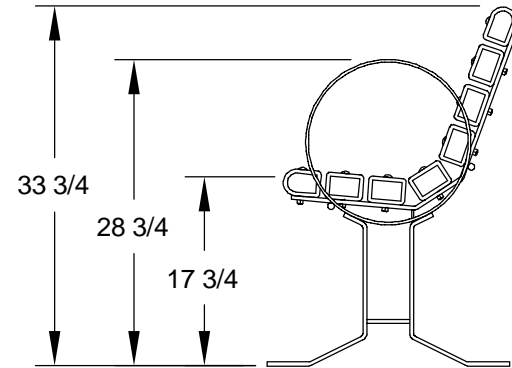
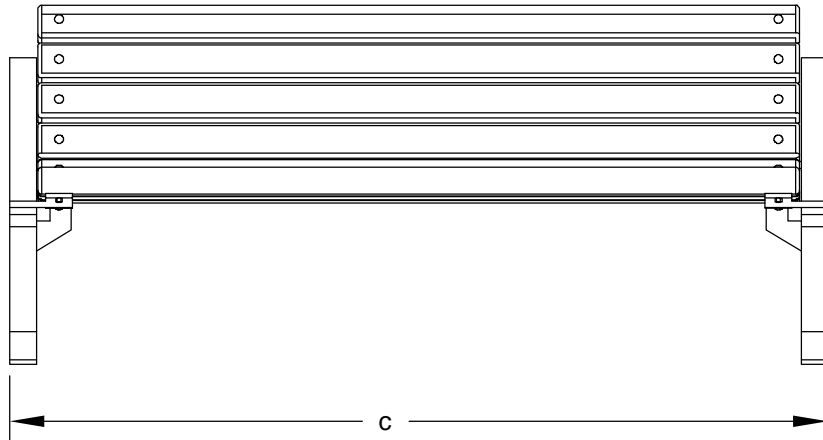

ALL DIMENSIONS IN INCHES

RJThomas Mfg. Co., Inc.
P.O. Box 946 • Cherokee, IA 51012-0946

DRAWN BY
WWM

TITLE **GREY CREEK SERIES MODEL B32 3, 4, AND, 6 FOOT CONTOUR SURFACE MOUNT BENCH WITH 3" x 4" LUMBER TIMBERS**

DATE **8-29-08**

DWG. NO. **AI-1500**