



Model BE32/CN-3IB34 3 Ft. Surface Mount Bench Extension with Green Powder Coat Frames and Indonesian Balau Wood 3" x 4" Timbers. (Shown with **Model B32/CN-3IB34** Bench.)

- **Comfortable contoured full back and seat design**
- **Designed to join easily with Model B32 benches to make longer benches with additional armrests**
- **Wide, comfortable armrest loops integrated into extension frames**
- **Sturdy, formed and welded steel frame construction**
- **Powder Coat or Hot-Dip Galvanized frame finish**
- **Precision drilled Hardwood 3" x 4" Timbers**
- **Quality construction throughout**

AVAILABLE OPTIONS

- **3' or 4' models**
- **Powder Coat Finish in choice of colors or Hot Dip Galvanized steel frame components**
- **Treated #1 Southern Yellow Pine or Construction Heart Redwood lumber**
- **Custom Lettering and Plaques available (call for details)**

SPECIFICATIONS:

- **Model BE32 Series** extension frame is one-piece welded construction with 3/8" x 2-1/2" A-36 flat steel bar legs and die-formed feet with 25/32" dia. anchor holes. Two back and seat brackets are constructed of 3/8" x 2-1/2" A-36 flat steel bar, die-formed for shape and reinforcement, with holes to mount eight 3" x 4" timbers. The circular armrest is formed from 1/4" x 2-1/2" flat steel bar.
- Model BE32 bench extension is used with Model B32 3 and 4 ft. benches. Multiple extensions can be added to create any length of bench in 3 and 4 ft. increments. The extension frame replaces one bench end frame which is then moved to the end of the extension. (For information on Model B32 benches refer to Specification Bulletin #SPC-BC-013.)
- **Model BE32-3** is a nom. 3 ft. in length.
- **Model BE32-4** is a nom. 4 ft. in length.
- Extension is designed to be permanently surface mounted using 25/32" dia. holes provided in each frame foot for use with concrete anchors (anchors not included).
- **Standard:** Frame is finished in Black powder coat (indicated by "/CB" in model no., e.g. BE32/CB-3IB34).
- **Standard:** Lumber is Indonesian Balau Wood 3" x 4" nominal sized timbers (indicated by "IB" in model no., e.g. BE32/CB-3IB34). All timbers are precision drilled for assembly and have all exposed edges removed to a 3/8" radius with a bullnose profile timber used on top and front positions.
- All fasteners are provided for assembly.
- **Optional:** Color choices of powder coated steel frame components. For optional colors choices see Specification Bulletin #SPC-CO-001.
- **Optional:** Frame is hot dip galvanized after fabrication to ASTM-A123 to maintain an average zinc coating of 2.0 oz. per sq. ft. of surface area. (To specify, change "/CB" in model no. to "/G", e.g. BE32/G-3IB34).
- **Optional:** Lumber is #1 grade Southern Yellow Pine, pressure treated and kiln dried after treatment (KDAT) to preserve wood against decay, or Construction Heart Redwood. (To specify, change "IB" in model no. to "TP" for Treated Pine, e.g. BE32/CB-3TP34, or to "CO" for Construction Heart Redwood, e.g. BE32/CB-3CO34).

RJThomas Mfg. Co., Inc.

PO Box 946 • Cherokee, IA 51012-0946 • PH: 712-225-5115 • 800-762-5002 • FAX: 712-225-5796
E-mail: pilotrock@rjthomas.com • Web Site: <http://www.pilotrock.com>

© 2008 RJThomas Mfg. Co., Inc. PILOT ROCK® Park Products is a registered trademark of RJThomas Mfg. Co., Inc.

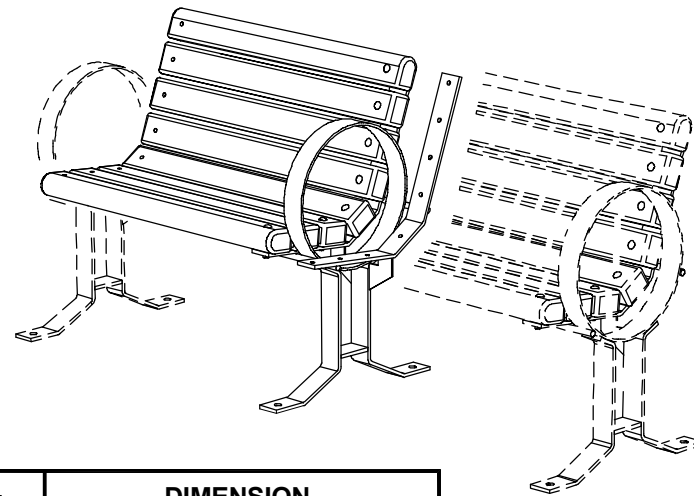
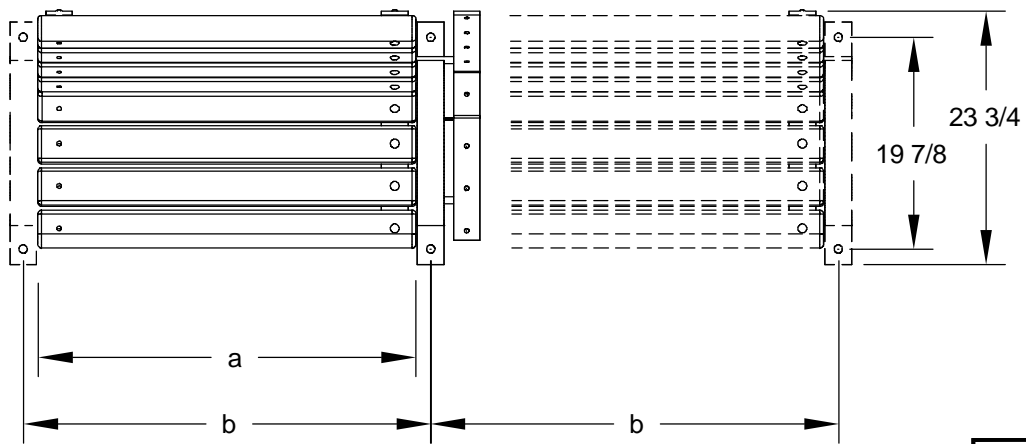

MODEL NUMBER	DIMENSION		
	a	b	c*
BE32-3	35 1/2	38 1/4	38 1/4
BE32-4	47 1/2	50 1/4	50 1/4

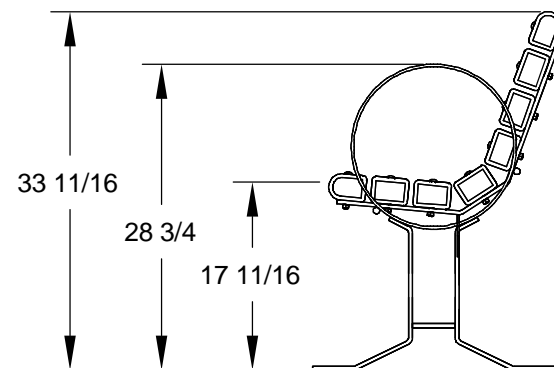
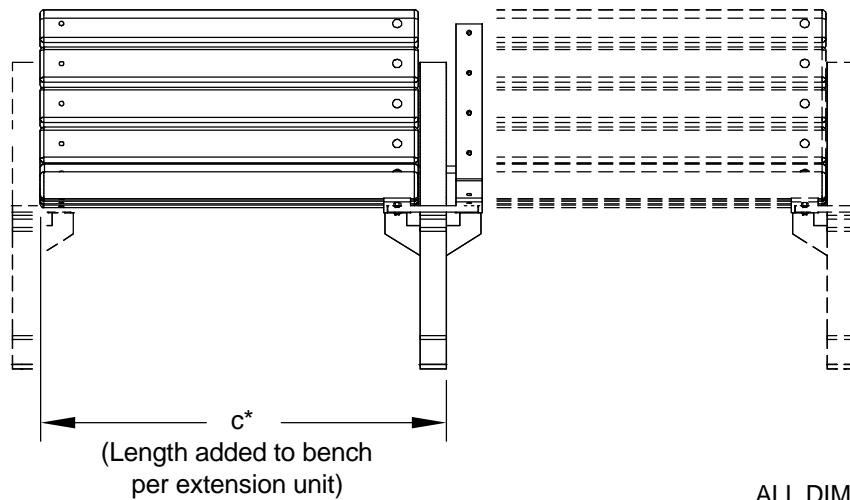

ALL DIMENSIONS IN INCHES

RJThomas Mfg. Co., Inc.
P.O. Box 946 • Cherokee, IA 51012-0946

DRAWN BY
WWM

TITLE GREY CREEK SERIES MODEL BE32 3 AND 4 FOOT CONTOUR BENCH EXTENSION WITH 3" x 4" LUMBER TIMBERS (SHOWN WITH GREY CREEK SERIES MODEL B32 BENCH IN PHANTOM)

DATE 8-29-08

DWG. NO. **AI-1536**