



Model BE33/CW-3IB34 3 Ft. Embedded Mount Bench Extension with Brown Powder Coat Frames and Indonesian Balau Wood 3" x 4" Timbers. (Shown with Model B33/CW-3IB34 Bench.)

- **Comfortable contoured full back and seat design**
- **Designed to join easily with Model B33 benches to make longer benches with additional armrests**
- **Wide, comfortable armrest loops integrated into extension frames**
- **Sturdy, formed and welded steel frame construction**
- **Powder Coat or Hot-Dip Galvanized frame finish**
- **Precision drilled Hardwood 3" x 4" Timbers**
- **Quality construction throughout**

AVAILABLE OPTIONS

- **3' or 4' models**
- **Powder Coat Finish in choice of colors or Hot Dip Galvanized steel frame components**
- **Treated #1 Southern Yellow Pine or Construction Heart Redwood lumber**
- **Custom Lettering and Plaques available (call for details)**

SPECIFICATIONS:

- **Model BE33 Series** extension frame is a one-piece welded construction with 3/8" x 2-1/2" A-36 flat steel bar legs. Two seat brackets are constructed of 3/8" x 2-1/2" A-36 flat steel bar, die-formed for shape and reinforcement, with holes to mount eight 3" x 4" timbers. The circular armrest is formed from 1/4" x 2-1/2" flat steel bar.
- Model BE33 bench extension is used with Model B33 3 and 4 ft. benches. Multiple extensions can be added to create any length of bench in 3 and 4 ft. increments. The extension frame replaces one bench end frame which is then moved to the end of the extension. (For information on Model B33 benches refer to Specification Bulletin #SPC-BC-019.)
- **Model BE33-3** is a nom. 3 ft. in length.
- **Model BE33-4** is a nom. 4 ft. in length.
- Bench is designed to be permanently anchored by embedding bench legs in concrete footings.
- **Standard:** Frame is finished in Black powder coat (indicated by "/CB" in model no., e.g. BE33/CB-3IB34).
- **Standard:** Lumber is Indonesian Balau Wood 3" x 4" nominal sized timbers (indicated by "IB" in model no., e.g. BE33/CB-3IB34). All timbers are precision drilled for assembly and have all exposed edges removed to a 3/8" radius with a bullnose profile timber used on top and front positions.
- All fasteners are provided for assembly.
- **Optional:** Color choices of powder coated steel frame components. For optional colors choices see Specification Bulletin #SPC-CO-001.
- **Optional:** Frame is hot dip galvanized after fabrication to ASTM-A123 to maintain an average zinc coating of 2.0 oz. per sq. ft. of surface area. (To specify, change "/CB" in model no. to "/G", e.g. BE33/G-3IB34).
- **Optional:** Lumber is #1 grade Southern Yellow Pine, pressure treated and kiln dried after treatment (KDAT) to preserve wood against decay, or Construction Heart Redwood. (To specify, change "IB" in model no. to "TP" for Treated Pine, e.g. BE33/CB-3TP34, or to "CO" for Construction Heart Redwood, e.g. BE33/CB-3CO34).

RJThomas Mfg. Co., Inc.

PO Box 946 • Cherokee, IA 51012-0946 • PH: 712-225-5115 • 800-762-5002 • FAX: 712-225-5796
E-mail: pilotrock@rjthomas.com • Web Site: <http://www.pilotrock.com>

© 2008 RJThomas Mfg. Co., Inc. PILOT ROCK® Park Products is a registered trademark of RJThomas Mfg. Co., Inc.

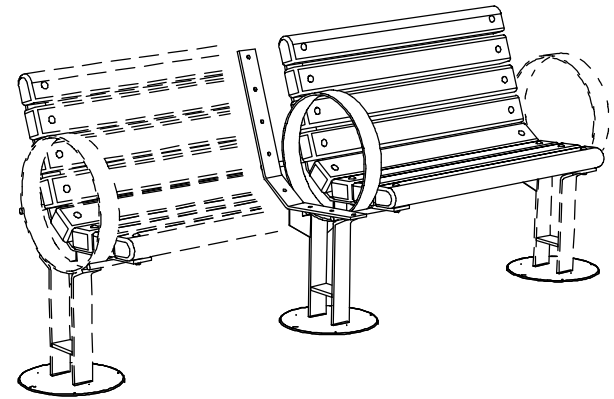
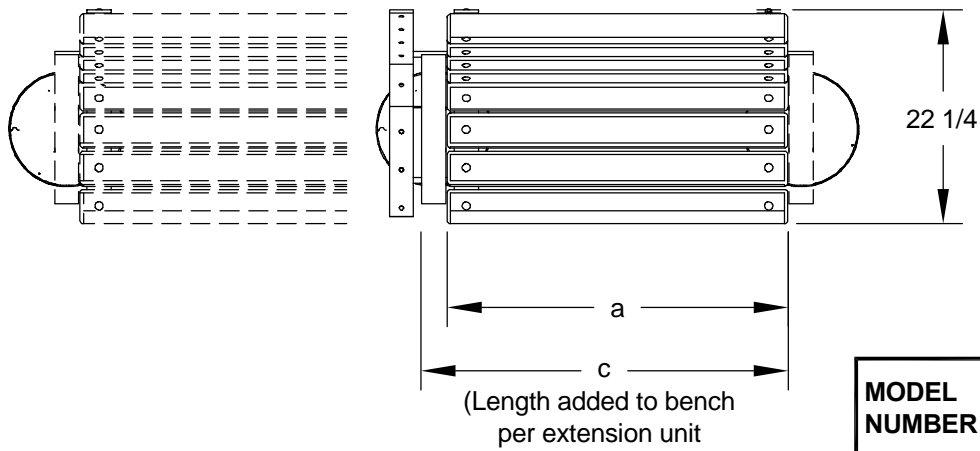

MODEL NUMBER	DIMENSION		
	a	b	c
BE33-3	35 1/2	38 1/4	38 1/4
BE33-4	47 1/2	50 1/4	50 1/4

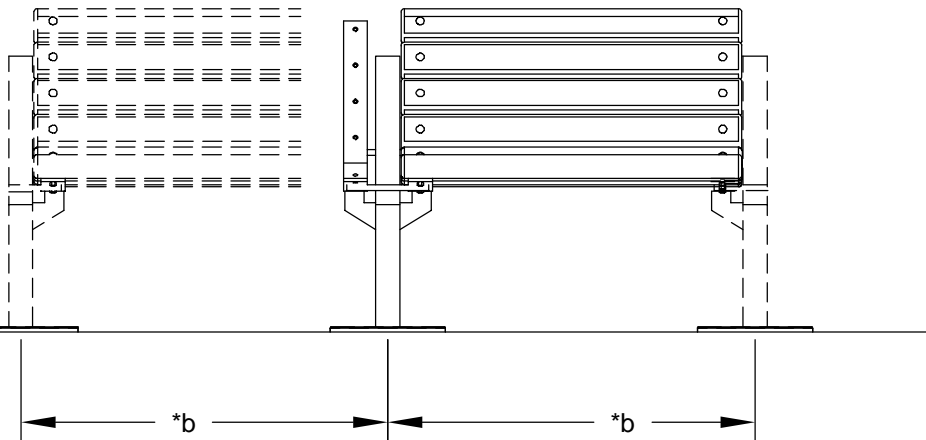

*CTR TO CTR
OF FRAME POSTS

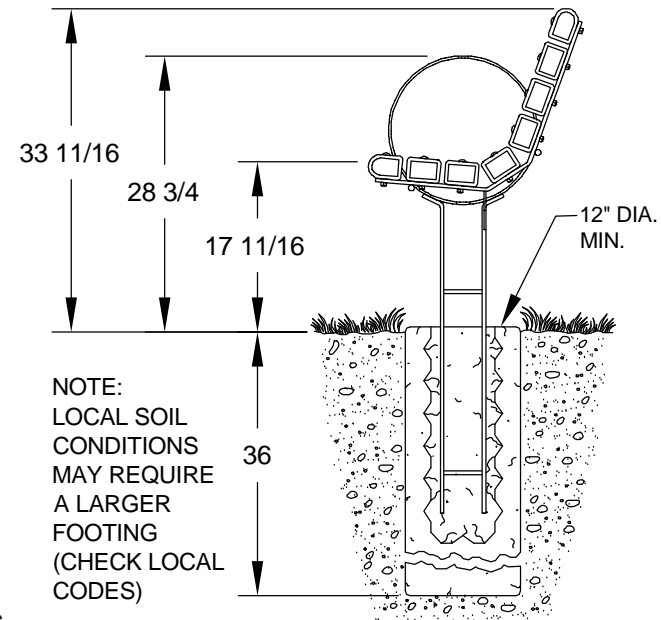

NOTE:
LOCAL SOIL
CONDITIONS
MAY REQUIRE
A LARGER
FOOTING
(CHECK LOCAL
CODES)

ALL DIMENSIONS IN INCHES

RJThomas Mfg. Co., Inc.
P.O. Box 946 • Cherokee, IA 51012-0946

DRAWN BY
WWM

TITLE GREY CREEK SERIES MODEL BE33 3 AND 4 FOOT CONTOUR EMBEDDED MOUNT BENCH
WITH 3" x 4" LUMBER TIMBERS (SHOWN WITH GREY CREEK SERIES MODEL B33 BENCH IN
PHANTOM)

DATE 8-29-08

DWG. NO. AI-1576