

**Silver Sioux Series, Model BE41  
Embedded Mount 3 and 4 Ft.  
Extension for Model B41 Bench  
with Lumber Timbers**

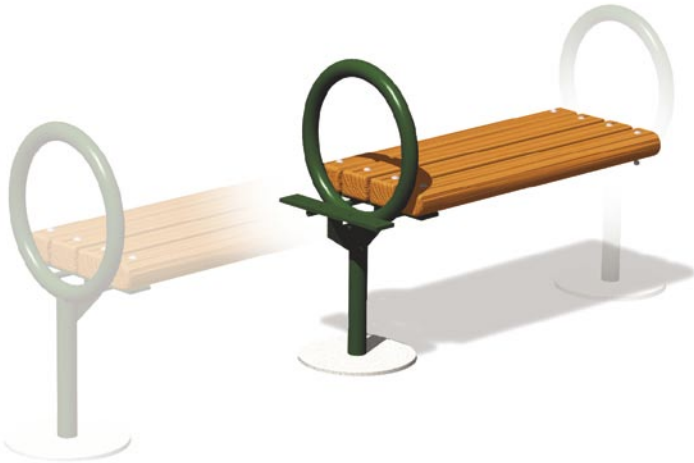

**Model BE41/CN-3IB34** 3 Ft. Embedded Mount Bench Extension with Green Powder Coat Frames and Indonesian Balau Wood 3" x 4" Timbers. (Shown with **Model B41/CN-3IB34** Bench.)

- **Comfortable seat design may be accessed from either side**
- **Designed to join easily with Model B41 benches to make longer benches with additional armrests**
- **Stylish armrest loops integrated into extension frames**
- **Sturdy, formed and welded steel frame construction**
- **Powder Coat frame finish**
- **Precision drilled Hardwood 3" x 4" Timbers**
- **Quality construction throughout**

**SPECIFICATIONS:**

- **Model BE41 Series** extension frame is a one-piece welded construction with 3/8" x 2-1/2" A-36 flat steel bar legs. Two seat brackets are constructed of 3/8" x 2-1/2" A-36 flat steel bar with holes to mount four 3" x 4" timbers. The extension frame includes a welded-on circular armrest formed from 1.66" O.D. steel tubing.
- Model BE41 bench extension is used with Model B41 3 and 4 ft. benches. Multiple extensions can be added to create any length of bench in 3 and 4 ft. increments. The extension frame replaces one bench end frame which is then moved to the end of the extension. (For information on Model B41 benches refer to Specification Bulletin #SPC-BC-031.)
- **Model BE41-3** is a nom. 3 ft. in length.
- **Model BE41-4** is a nom. 4 ft. in length.
- Bench is designed to be permanently anchored by embedding bench legs in concrete footings.
- **Standard:** Frame is finished in Black powder coat (indicated by "/CB" in model no., e.g. BE41/CB-3IB34).
- **Standard:** Lumber is Indonesian Balau Wood 3" x 4" nominal sized timbers (indicated by "IB" in model no., e.g. BE41/CB-3IB34). All timbers are precision drilled for assembly and have all exposed edges removed to a 3/8" radius with a bullnose profile timber used on outside positions.
- All fasteners are provided for assembly.
- **Optional:** Color choices of powder coated steel frame components. For optional colors choices see Specification Bulletin #SPC-CO-001.
- **Optional:** Lumber is #1 grade Southern Yellow Pine, pressure treated and kiln dried after treatment (KDAT) to preserve wood against decay, or Construction Heart Redwood. (To specify, change "IB" in model no. to "TP" for Treated Pine, e.g. BE41/CB-3TP34, or to "CO" for Construction Heart Redwood, e.g. BE41/CB-3CO34).

**AVAILABLE OPTIONS**

- 3' or 4' models
- Choice of colors of Powder Coat Finish on steel frame components
- Treated #1 Southern Yellow Pine or Construction Heart Redwood lumber
- Custom Lettering and Plaques available (call for details)

**RJThomas Mfg. Co., Inc.**

PO Box 946 • Cherokee, IA 51012-0946 • PH: 712-225-5115 • 800-762-5002 • FAX: 712-225-5796  
E-mail: pilotrock@rjthomas.com • Web Site: <http://www.pilotrock.com>

© 2008 RJThomas Mfg. Co., Inc. PILOT ROCK® Park Products is a registered trademark of RJThomas Mfg. Co., Inc.

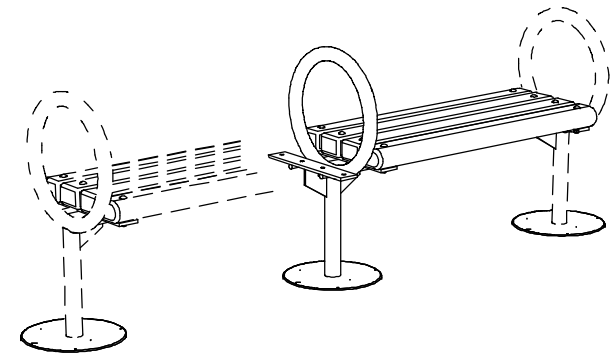
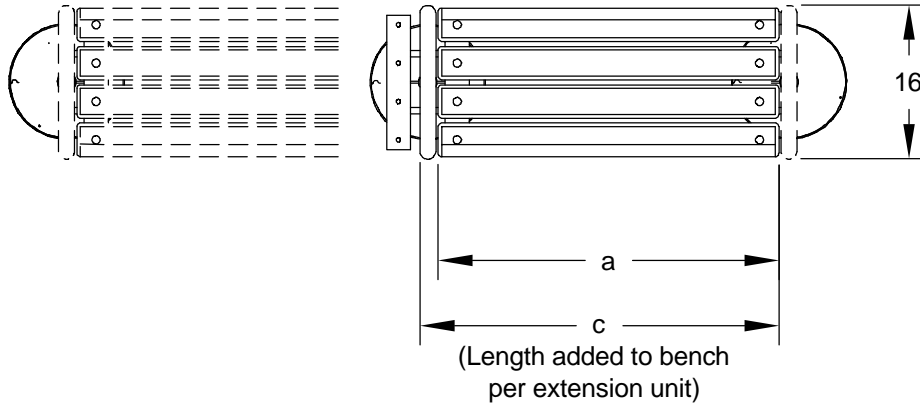

MODEL NUMBER	DIMENSION		
	a	*b	c
BE41-3	35 1/2	37 5/8	37 5/8
BE41-4	47 1/2	49 5/8	49 5/8

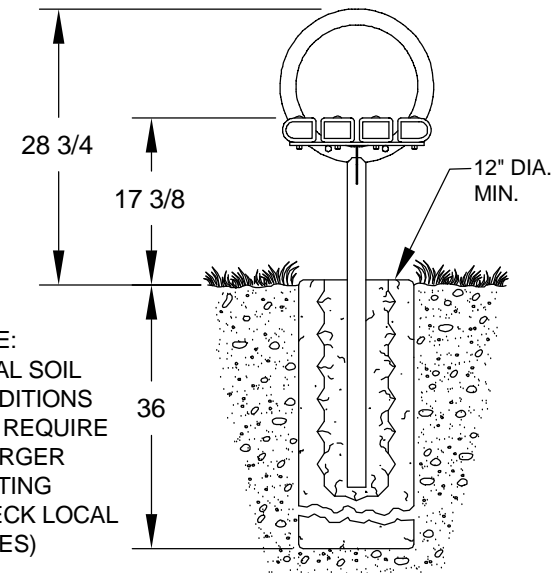
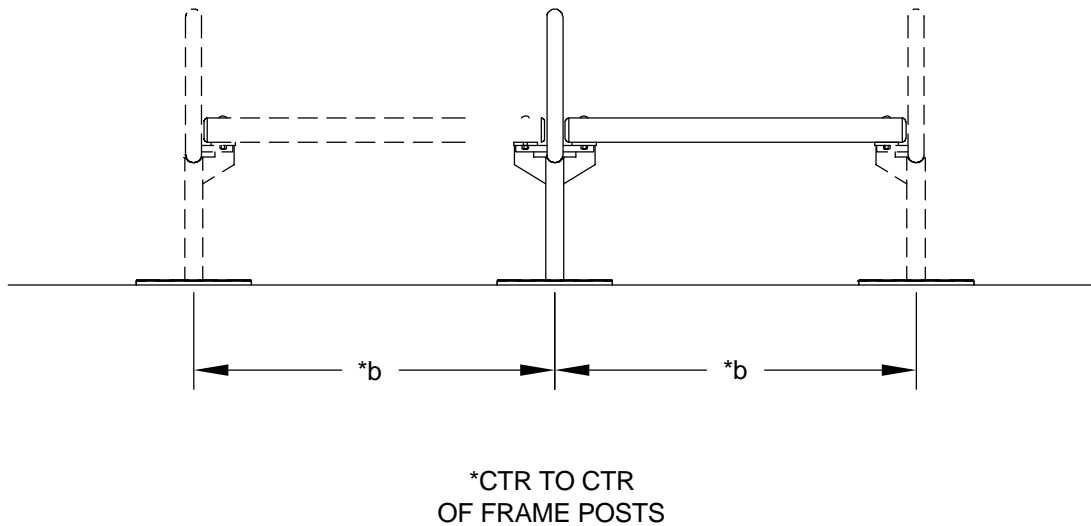

ALL DIMENSIONS IN INCHES

**RJThomas Mfg. Co., Inc.**  
P.O. Box 946 • Cherokee, IA 51012-0946

DRAWN BY  
**WWM**

TITLE SILVER SIOUX SERIES MODEL BE41 3 AND 4 FOOT FLAT EMBEDDED MOUNT BENCH EXTENSIONS WITH 3" x 4" LUMBER TIMBERS (SHOWN WITH SILVER SIOUX SERIES MODEL B41 BENCH IN PHANTOM)

DATE 8-27-08

DWG. NO. AI-1582