

Silver Sioux Series, Model B42C Surface Mount 8 Ft. Bench with Lumber Timbers



*Model B42C/CB-8IB34 8 Ft. Surface Mount Bench
with Black Powder Coat Frames
and Indonesian Balau Wood 3" x 4" Timbers.*

- **Comfortable contoured full back and seat design**
- **Stylish armrest loops integrated into end frames**
- **Sturdy, formed and welded steel frame construction**
- **Powder Coat frame finish**
- **Precision drilled Hardwood 3" x 4" Timbers**
- **Quality construction throughout**

SPECIFICATIONS:

- **Model B42C Series** end frames are one-piece welded construction with frame leg and foot to meet 1-1/2" nominal steel pipe size specifications (1-7/8" O.D.). Frame foot is die-formed with flattened and rounded ends, with a 9/16" dia. anchor hole in each end. Seat brackets are constructed of 2-3/8" x 1-1/2" x 1/8" nominal sized, die-formed channel, with holes to mount eight 3" x 4" timbers. The end frames include a welded-on circular armrest formed from 1.66" O.D. steel tubing.
- **Model B42C-8** is a nom. 8 ft. in length.
- Bench is designed to be permanently surface mounted using 9/16" dia. holes provided in each frame foot for use with concrete anchors (anchors not included).
- Bench is provided with a center frame for additional support (indicated by "B42C" in model no., e.g. B42C/CB-8IB34). Center frame does not have armrest.
- **Standard:** Frames are finished in Black powder coat (indicated by "/CB" in model no., e.g. B42C/CB-8IB34).
- **Standard:** Lumber is Indonesian Balau Wood 3" x 4" nominal sized timbers (indicated by "IB" in model no., e.g. B42C/CB-8IB34). All timbers are precision drilled for assembly and have all exposed edges removed to a 3/8" radius with a bullnose profile timber used on top and front positions.
- All fasteners are provided for assembly.
- **Optional:** Color choices of powder coated steel frame components. For optional colors choices see Specification Bulletin #SPC-CO-001.
- **Optional:** Lumber is #1 grade Southern Yellow Pine, pressure treated and kiln dried after treatment (KDAT) to preserve wood against decay, or Construction Heart Redwood. (To specify, change "IB" in model no. to "TP" for Treated Pine, e.g. B42C/CB-8TP34, or to "CO" for Construction Heart Redwood, e.g. B42C/CB-8CO34.)

AVAILABLE OPTIONS

- **Choice of colors of Powder Coat Finish on steel frame components**
- **Treated #1 Southern Yellow Pine or Construction Heart Redwood lumber**
- **Custom Lettering and Plaques available (call for details)**

RJThomas Mfg. Co., Inc.

PO Box 946 • Cherokee, IA 51012-0946 • PH: 712-225-5115 • 800-762-5002 • FAX: 712-225-5796
E-mail: pilotrock@rjthomas.com • Web Site: <http://www.pilotrock.com>

© 2008 RJThomas Mfg. Co., Inc. PILOT ROCK® Park Products is a registered trademark of RJThomas Mfg. Co., Inc.

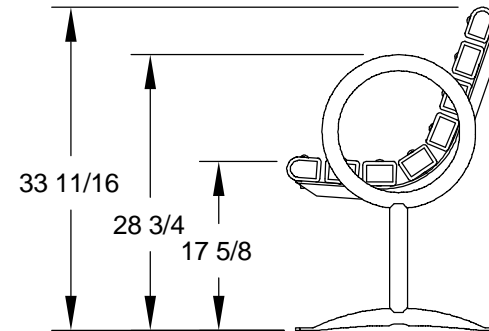
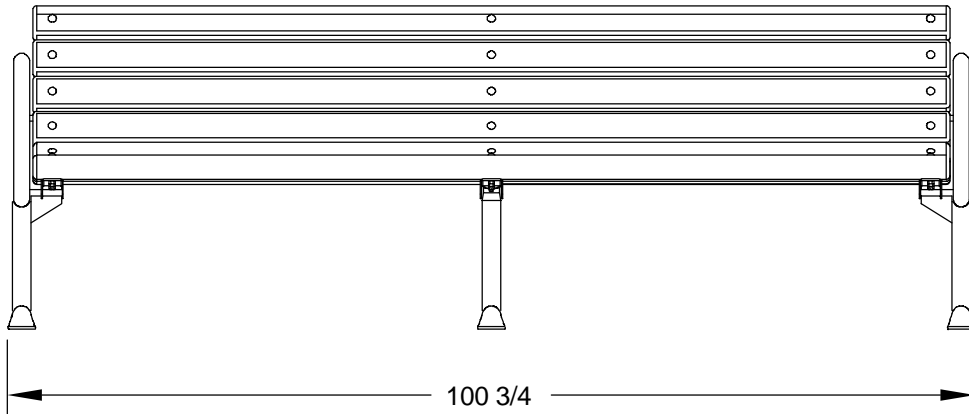
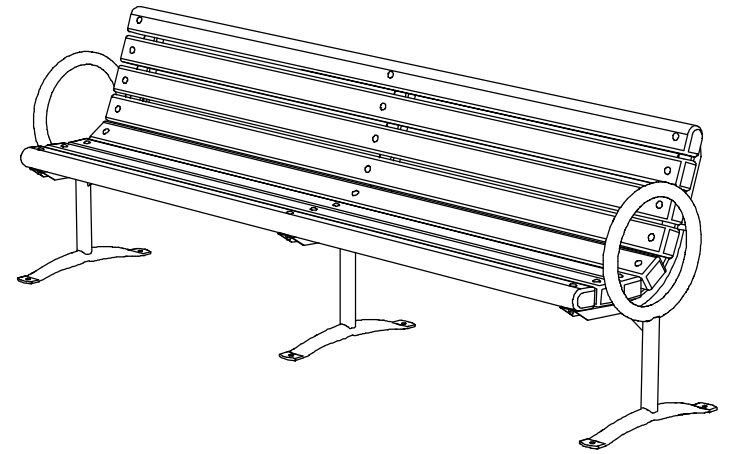
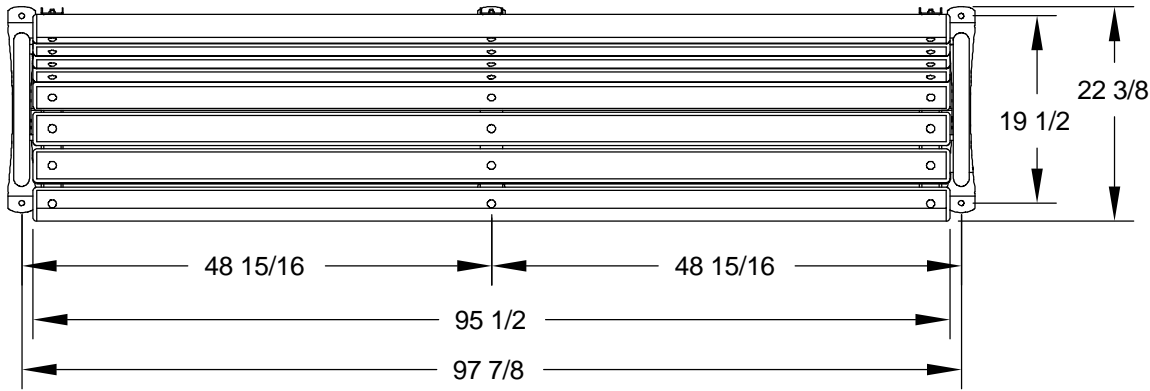

ALL DIMENSIONS IN INCHES

RJThomas Mfg. Co., Inc.
P.O. Box 946 • Cherokee, IA 51012-0946

DRAWN BY
WWM

TITLE **SILVER SIOUX SERIES MODEL B42C 8 FOOT CONTOUR SURFACE MOUNT BENCH WITH 3" X 4" LUMBER TIMBERS**

DATE **8-27-08**

DWG. NO. **AI-1534**