



Model BE43/CW-3IB34 3 Ft. Embedded Mount Bench Extension with Brown Powder Coat Frames and Indonesian Balau Wood 3" x 4" Timbers. (Shown with **Model B43/CW-3IB34** Bench.)

- **Comfortable contoured full back and seat design**
- **Designed to join easily with Model B43 benches to make longer benches with additional armrests**
- **Stylish armrest loops integrated into extension frames**
- **Sturdy, formed and welded steel frame construction**
- **Powder Coat frame finish**
- **Precision drilled Hardwood 3" x 4" Timbers**
- **Quality construction throughout**

SPECIFICATIONS:

- **Model BE43 Series** extension frame is a one-piece welded construction with 3/8" x 2-1/2" A-36 flat steel bar legs. Two seat brackets are constructed of 3/8" x 2-1/2" A-36 flat steel bar, die-formed for shape and reinforcement, with holes to mount eight 3" x 4" timbers. The extension frame includes a welded-on circular armrest formed from 1.66" O.D. steel tubing.
- Model BE43 bench extension is used with Model B43 3 and 4 ft. benches. Multiple extensions can be added to create any length of bench in 3 and 4 ft. increments. The extension frame replaces one bench end frame which is then moved to the end of the extension. (For information on Model B43 benches refer to Specification Bulletin #SPC-BC-043.)
- **Model BE43-3** is a nom. 3 ft. in length.
- **Model BE43-4** is a nom. 4 ft. in length.
- Bench is designed to be permanently anchored by embedding bench legs in concrete footings.
- **Standard:** Frame is finished in Black powder coat (indicated by "/CB" in model no., e.g. BE43/CB-3IB34).
- **Standard:** Lumber is Indonesian Balau Wood 3" x 4" nominal sized timbers (indicated by "IB" in model no., e.g. BE43/CB-3IB34). All timbers are precision drilled for assembly and have all exposed edges removed to a 3/8" radius with a bullnose profile timber used on top and front positions.
- All fasteners are provided for assembly.
- **Optional:** Color choices of powder coated steel frame components. For optional colors choices see Specification Bulletin #SPC-CO-001.
- **Optional:** Lumber is #1 grade Southern Yellow Pine, pressure treated and kiln dried after treatment (KDAT) to preserve wood against decay, or Construction Heart Redwood. (To specify, change "IB" in model no. to "TP" for Treated Pine, e.g. BE43/CB-3TP34, or to "CO" for Construction Heart Redwood, e.g. BE43/CB-3CO34).

AVAILABLE OPTIONS

- **3' or 4' models**
- **Choice of colors of Powder Coat Finish on steel frame components**
- **Treated #1 Southern Yellow Pine or Construction Heart Redwood lumber**
- **Custom Lettering and Plaques available (call for details)**

RJThomas Mfg. Co., Inc.

PO Box 946 • Cherokee, IA 51012-0946 • PH: 712-225-5115 • 800-762-5002 • FAX: 712-225-5796
E-mail: pilotrock@rjthomas.com • Web Site: <http://www.pilotrock.com>

© 2008 RJThomas Mfg. Co., Inc. PILOT ROCK® Park Products is a registered trademark of RJThomas Mfg. Co., Inc.

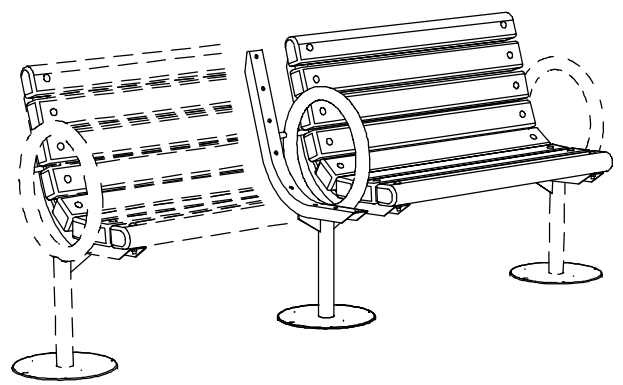
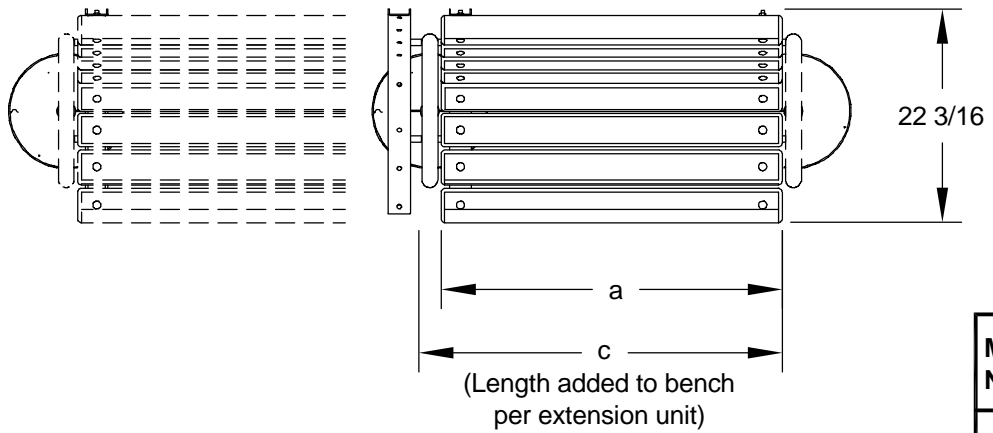

MODEL NUMBER	DIMENSION		
	a	*b	c
BE43-3	35 1/2	37 7/8	37 7/8
BE43-4	47 1/2	49 7/8	49 7/8

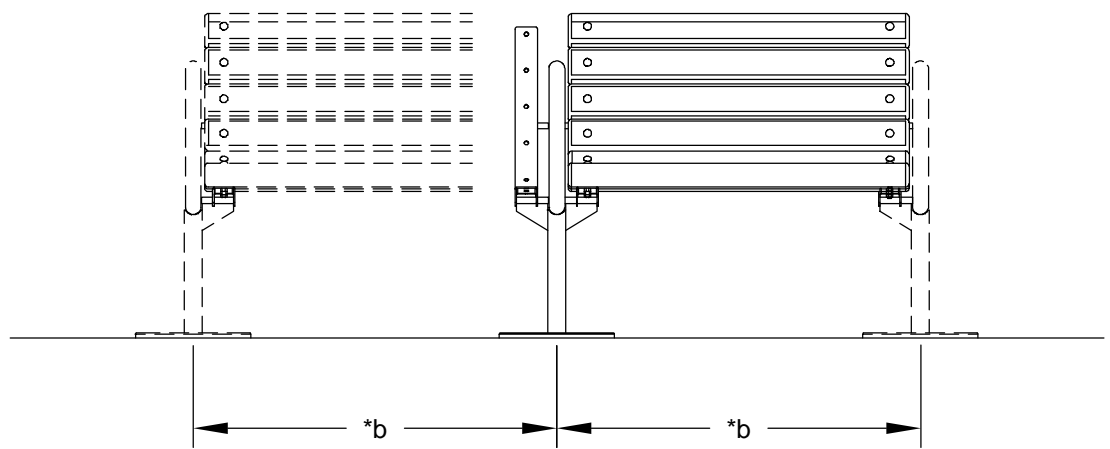

*CTR TO CTR OF FRAME POSTS

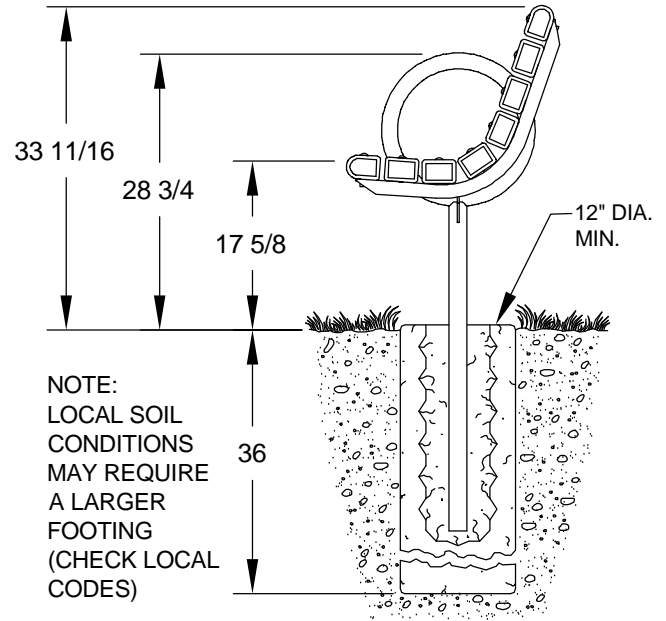

ALL DIMENSIONS IN INCHES

RJThomas Mfg. Co., Inc.
P.O. Box 946 • Cherokee, IA 51012-0946

DRAWN BY
WWM

TITLE SILVER SIOUX SERIES MODEL BE43 3 AND 4 FOOT CONTOUR EMBEDDED MOUNT BENCH EXTENSIONS WITH 3" x 4" LUMBER TIMBERS (SHOWN WITH SILVER SIOUX SERIES MODEL B43 BENCH IN PHANTOM)

DATE 8-27-08

DWG. NO. AI-1588