

Model BE60/CB-3IB34 Surface Mount Bench Extension with Black Powder Coat Frames, 3 Ft. long with Indonesian Balau Wood 3" x 4" Timbers. (Shown with Model B60/CB-3IB34 Bench.)

- **Comfortable seat design may be accessed from either side**
- **Designed to join easily with Model B60 benches to make longer benches with additional armrests**
- **Wide curves at the corners of the frames also serve as comfortable armrests**
- **Sturdy, formed and welded steel frame construction**
- **Powder Coat frame finish**
- **Precision drilled Hardwood 3" x 4" Timbers**
- **Quality construction throughout**

SPECIFICATIONS:

- **Model BE60 Series** extension frame is a one-piece welded construction with frame to meet 2" nominal steel pipe size specifications (2-3/8" O.D.) and each corner to be formed on a nominal 6" centerline radius. Two seat brackets are constructed of 3-1/8" x 2" x 7 ga. die-formed steel angle with holes to mount six 3" x 4" timbers.
- Model BE60 bench extension is used with Model B60 3 and 4 ft. benches. Multiple extensions can be added to create any length of bench in 3 and 4 ft. increments. The extension frame replaces one bench end frame which is then moved to the end of the extension. (For information on Model B60 benches refer to Specification Bulletin #SPC-BC-073.)
- Bench is designed to be permanently surface mounted using 9/16" dia. holes provided in each base plate for use with concrete anchors (anchors not included).
- **Model BE60-3** is a nom. 3 ft. in length.
- **Model BE60-4** is a nom. 4 ft. in length.
- **Standard:** Frame is finished in Black powder coat (indicated by "/CB" in model no., e.g. BE60/CB-3IB34).
- **Standard:** Lumber is Indonesian Balau Wood 3" x 4" nominal sized timbers (indicated by "IB" in model no., e.g. BE60/CB-3IB34). All timbers are precision drilled for assembly and have all exposed edges removed to a 3/8" radius with a bullnose profile timber used on outside positions.
- All fasteners are provided for assembly.
- **Optional:** Color choices of powder coated steel frame components. For optional colors choices see Specification Bulletin #SPC-CO-001.
- **Optional:** Lumber is #1 grade Southern Yellow Pine, pressure treated and kiln dried after treatment (KDAT) to preserve wood against decay, or Construction Heart Redwood. (To specify, change "IB" in model no. to "TP" for Treated Pine, e.g. BE60/CB-3TP34, or to "CO" for Construction Heart Redwood, e.g. BE60/CB-3CO34).

AVAILABLE OPTIONS

3' or 4' models

Choice of colors of Powder Coat Finish on steel frame components

Treated #1 Southern Yellow Pine or Construction Heart Redwood lumber

Custom Lettering and Plaques available (call for details)

RJThomas Mfg. Co., Inc.

PO Box 946 • Cherokee, IA 51012-0946 • PH: 712-225-5115 • 800-762-5002 • FAX: 712-225-5796

E-mail: pilotrock@rjthomas.com • Web Site: <http://www.pilotrock.com>

© 2008 RJThomas Mfg. Co., Inc. PILOT ROCK® Park Products is a registered trademark of RJThomas Mfg. Co., Inc.

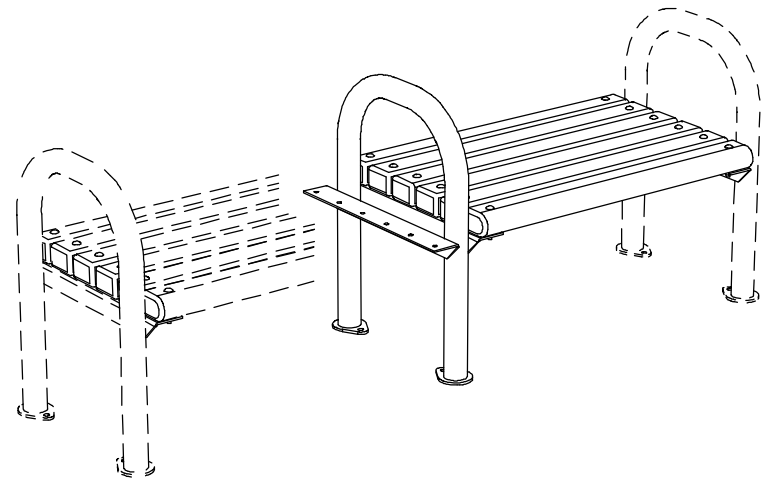
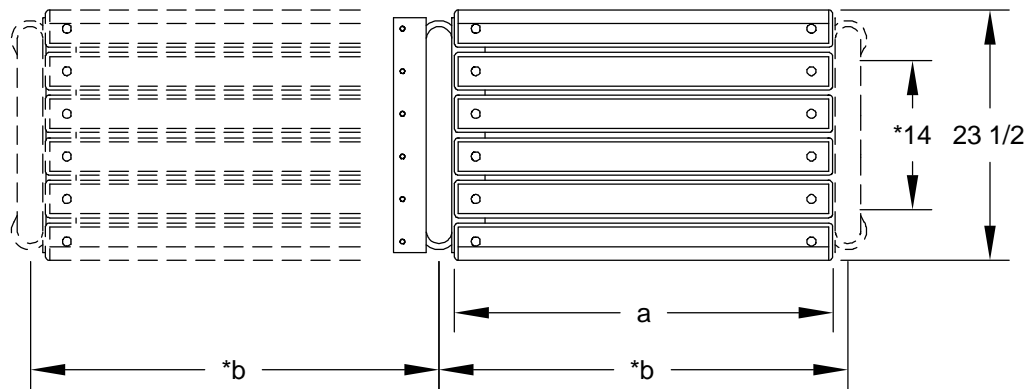

*CTR TO CTR OF MOUNTING HOLES

MODEL NUMBER	DIMENSION		
	a	*b	c
BE60-3	35 1/2	38 3/8	38 3/8
BE60-4	47 1/2	50 3/8	50 3/8

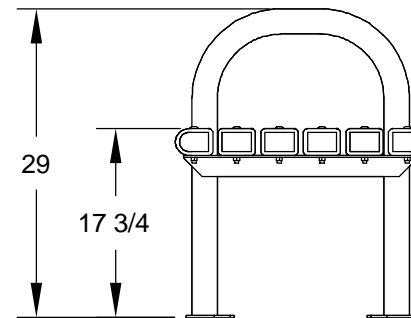
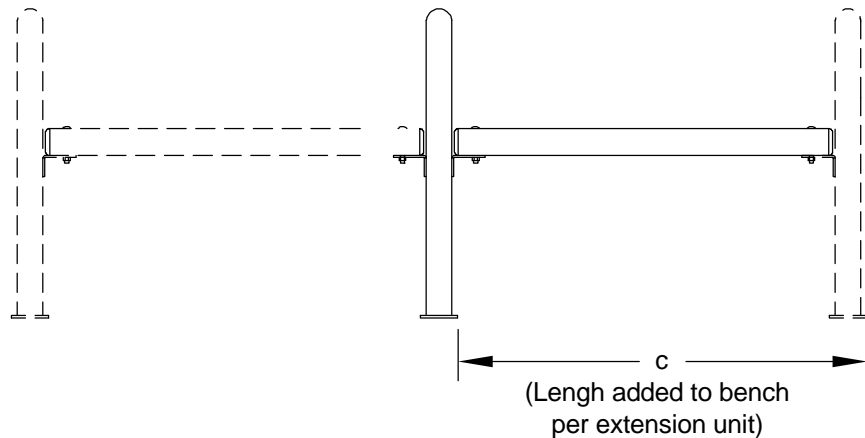

ALL DIMENSIONS IN INCHES

RJThomas Mfg. Co., Inc.
P.O. Box 946 • Cherokee, IA 51012-0946

DRAWN BY
WWM

TITLE RIVERVIEW SERIES MODEL; BE60 3 AND 4 FOOT FLAT SURFACE MOUNT BENCH EXTENSIONS WITH 3" X 4" LUMBER TIMBERS (SHOWN WITH RIVERVIEW SERIES MODEL B60 BENCH IN PHANTOM)

DATE 8-28-08

DWG. NO. **AI-1555**