



Model APB/P/G-8VA10 Surface Mount Bench
with Hot Dip Galvanized Frames, 8 Ft. long
with 10" wide Gray Plastisol Coated V-Type Expanded Steel seat.
Shown with optional base plate for surface mounting

- **Sturdy bench for permanent locations**
- **Frames are hot dip galvanized after fabrication for superior corrosion resistance**
- **Plastisol Coating heat fused to Expanded Steel Seat for durability**
- **Vinyl Plastisol formulated with U.V. stabilizers for ultraviolet protection**
- **Quality construction throughout**

AVAILABLE OPTIONS

- **6' or 8' models**
- **Powder Coat Finish in choice of colors for steel frame components**
- **Choice of colors of Plastisol Coating**
- **Base plate for surface mounting**

SPECIFICATIONS:

- **Model APB** seat frames are one-piece welded construction, fabricated from 3" x 6" x 1/8" wall rectangular structural steel tubing with 2" x 2" x 3/16" A-36 structural grade steel angle for attaching the seat material. Exposed ends of rectangular tubing are permanently sealed with welded-on steel end caps. Legs are designed to be embedded in concrete footings.
- **Model APB-6** is a nom. 6 ft. in length.
- **Model APB-8** is a nom. 8 ft. in length.
- Nominal seat height is 18".
- **Standard:** Frames are hot-dip galvanized after fabrication to ASTM-A123 to maintain an average zinc coating of 2.0 oz. per sq. ft. of surface area (indicated by "/G" in model no., e.g. APB/G-6VW10).
- **Standard:** Bench seat is a 10" wide (indicated by "10" at end of model number, e.g. APB/G-6VW10), one-piece welded construction, fabricated from a 3/4-#9 expanded steel surface with 10 ga. x 2-1/2" roll-formed vertical edges on all sides and reinforced by a 10 ga. x 2-1/4" x 1-1/4" die-formed angle substructure. Substructure includes all mounting holes for easy assembly.
- **Standard:** All steel surfaces of the seat are covered with a coating of brown (indicated by "VW" in model number, e.g. APB/G-6VW10) vinyl Plastisol formulated with high impact additives and UV inhibitors. Plastisol coating is permanently heat-fused to the steel to an average thickness of 125 mils (1/8") for an overall average thickness, including top and bottom coatings, of 250 mils (1/4").
- All fasteners are provided for assembly.
- **Optional:** Color choices of powder coated steel frame components. For optional colors choices see Specification Bulletin #SPC-CO-001.
- **Optional:** Color choices of plastisol coated steel components. For optional colors choices see Specification Bulletin #SPC-CO-001.
- **Optional:** Seat is available in a 12" width. Specify by changing "10" at end of model number to "12", e.g. APB/P/G-6VW12.
- **Optional:** Frames have a 3/8" x 8" x 8" steel base plate with four 25/32" dia. holes to bolt bench to concrete pad. To specify add "/P" after the "APB" in the model no., e.g. APB/P/G-6VW10. (Anchor bolts not included.)

RJThomas Mfg. Co., Inc.

PO Box 946 • Cherokee, IA 51012-0946 • PH: 712-225-5115 • 800-762-5002 • FAX: 712-225-5796
E-mail: pilotrock@rjthomas.com • Web Site: <http://www.pilotrock.com>

© 2008 RJThomas Mfg. Co., Inc. PILOT ROCK® Park Products is a registered trademark of RJThomas Mfg. Co., Inc.

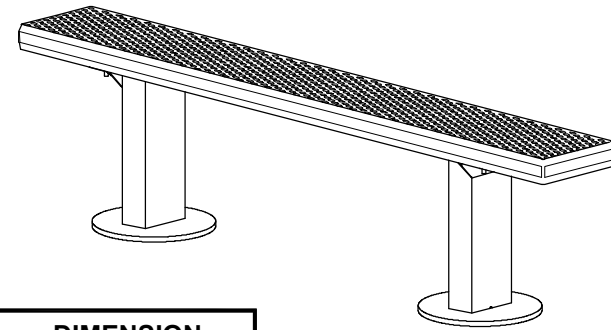
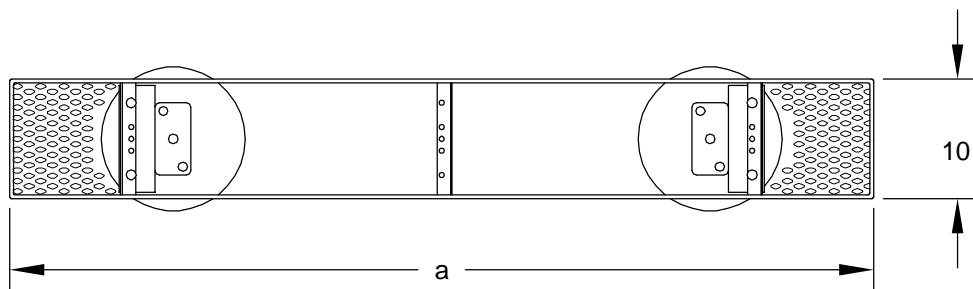

MODEL NUMBER	DIMENSION	
	a	b
APB-6	72	44-3/4
APB-8	96	63

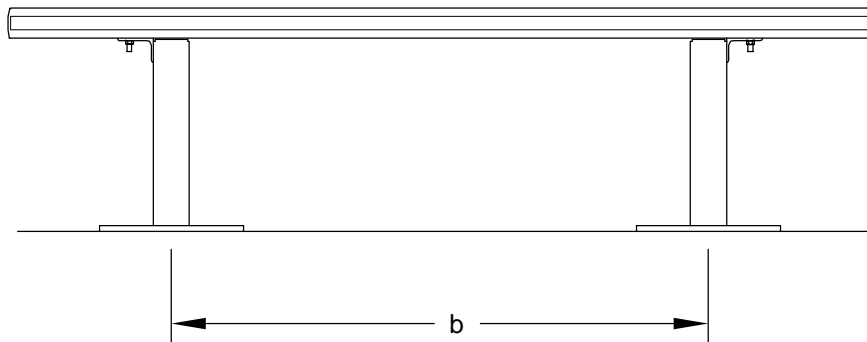

NOTE:
LOCAL SOIL
CONDITIONS
MAY REQUIRE
A LARGER
FOOTING
(CHECK LOCAL
CODES)

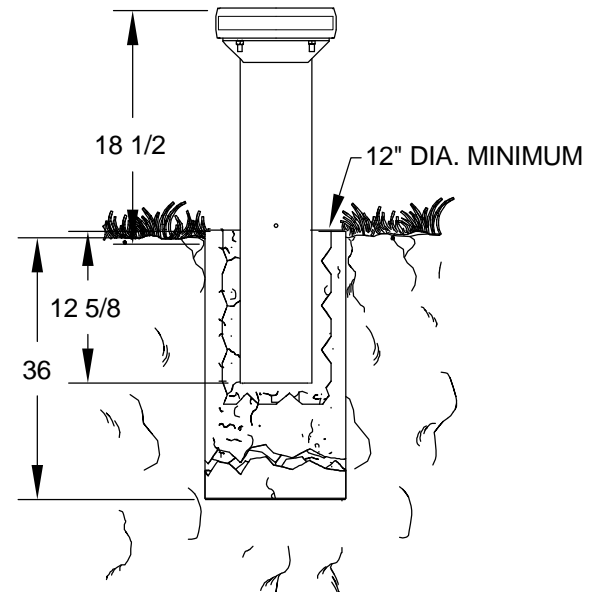

ALL DIMENSIONS IN INCHES

RJThomas Mfg. Co., Inc.
P.O. Box 946 • Cherokee, IA 51012-0946

DRAWN BY
WWM

TITLE MODEL APB 6 AND 8 FOOT EMBEDDED MOUNT DOUBLE PEDESTAL BENCH WITH
10" WIDE PLASTISOL COATED EXPANDED STEEL SEAT

DATE 9-05-08

DWG. NO. AI-1632