

Model SCXB Embedded Mount 4, 6, and 8 Ft. Bench with Lumber Back and Seat



*Model SCXB/G-6TP24 Embedded Mount Bench
with Hot-Dip Galvanized Frames,
6 Ft. long with Treated Southern Yellow Pine 2" x 4" Slats.*

- **Extra heavy design to be stronger and more stable with a simple, clean style**
- **Sturdy, formed and welded steel frame construction**
- **Frames are Hot-Dip Galvanized after fabrication for superior corrosion resistance**
- **Precision drilled lumber**
- **Quality construction throughout**

SPECIFICATIONS:

- **Model SCXB** end frames are one-piece, welded construction with a back and seat bracket of 2-3/8" x 1-1/2" x 1/8" nominal sized, die-formed channel, and a 2.375" (2-3/8") O.D. post to meet 2" nominal steel pipe size specifications. Bench leg is designed to be permanently embedded in concrete footings.
- **Model SCXB/G-4** is 4 ft. long (nom.).
- **Model SCXB/G-6** is 6 ft. long (nom.).
- **Model SCXB/G-8** is 8 ft. long (nom.).
- **Standard:** All steel frame components are hot-dip galvanized after fabrication to ASTM-A123 to maintain an average zinc coating of 2.0 oz. per sq. ft. of surface area (indicated by "/G" in model no., e.g. SCXB/G-4TP24).
- **Standard:** Seat and back are (6) 2" x 4" (nom.) Treated #1 Southern Yellow Pine slats, pressure treated and kiln dried after treatment (KDAT) to preserve wood against decay (indicated by "TP24" at end of the model no, e.g. SCXB/G-4TP24).
- All fasteners are provided for assembly.
- **Optional:** Color choices of powder coated steel frame components. For optional colors choices see Specification Bulletin #SPC-CO-001.
- **Optional:** Untreated #1 Southern Yellow Pine seat and back is readily available (To specify, change "TP" in model no. to "UP", e.g. SCXB/G-4UP24). (Cedar, Fir, and Redwood are available when in stock – please inquire.)

AVAILABLE OPTIONS

- 4', 6' or 8' models
- Powder Coat Finish in choice of colors for steel frame components
- Untreated #1 Southern Yellow Pine, Cedar, Fir, or Redwood lumber
- Custom Lettering and Plaques available (call for details)
- Armrests

RJThomas Mfg. Co., Inc.

PO Box 946 • Cherokee, IA 51012-0946 • PH: 712-225-5115 • 800-762-5002 • FAX: 712-225-5796
E-mail: pilotrock@rjthomas.com • Web Site: <http://www.pilotrock.com>

© 2008 RJThomas Mfg. Co., Inc. PILOT ROCK® Park Products is a registered trademark of RJThomas Mfg. Co., Inc.

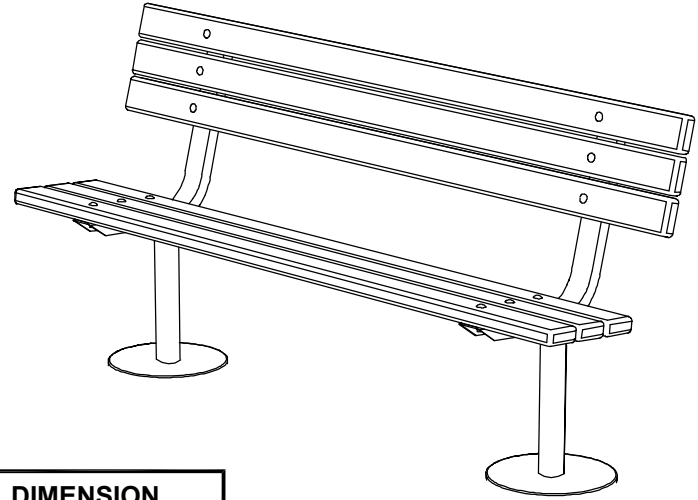
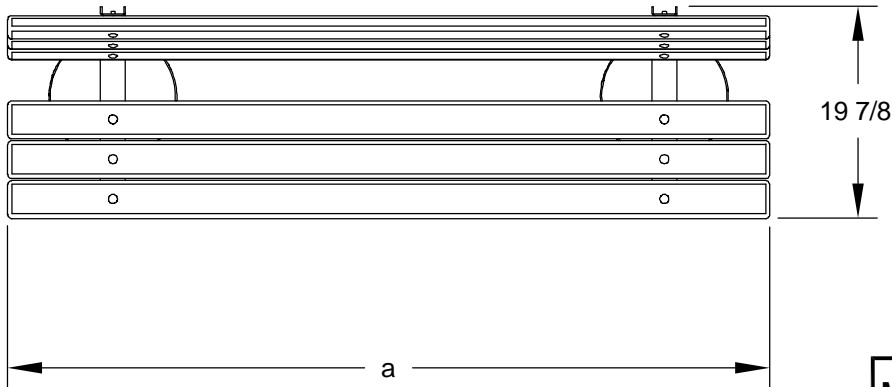

MODEL NUMBER	DIMENSION	
	a	b
SCXB-4	47-1/2	36
SCXB-6	71-1/2	51-3/4
SCXB-8	95-1/2	70

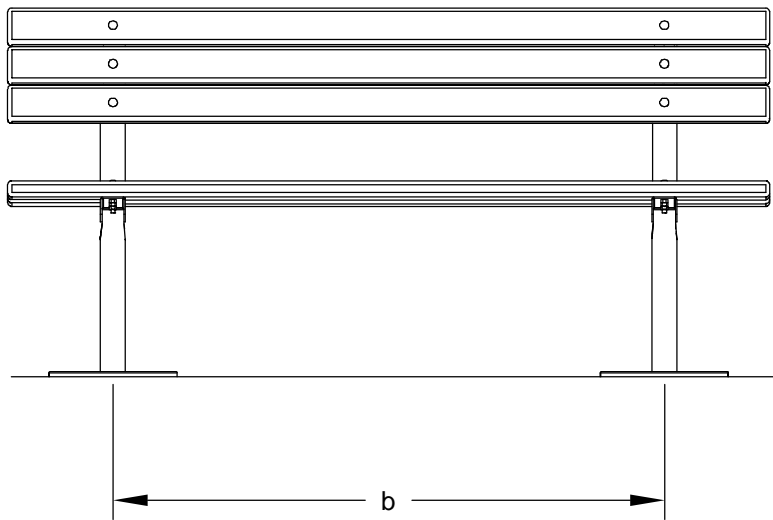

*CTR TO CTR
OF FRAME POSTS

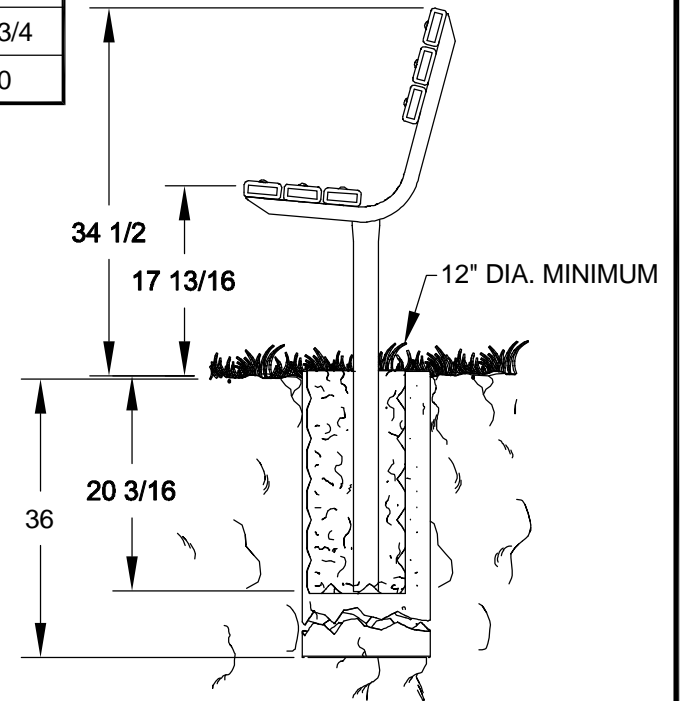

NOTE:
LOCAL SOIL
CONDITIONS
MAY REQUIRE
A LARGER
FOOTING
(CHECK LOCAL
CODES)

ALL DIMENSIONS IN INCHES

RJThomas Mfg. Co., Inc.
P.O. Box 946 • Cherokee, IA 51012-0946

DRAWN BY
WWM

TITLE MODEL SCXB EXTRA HEAVY DUTY 4, 6, AND 8 FOOT EMBEDDED MOUNT BENCH
WITH 2" X 4" LUMBER SLATS

DATE 9-03-08

DWG. NO. AI-1627