

Model PCXB Portable or Surface Mount 4 and 6 Ft. Bench with Recycled Plastic Back and Seat



Model PCXB/G-4PN24 Surface Mount Bench
with Hot-Dip Galvanized Frames,
4 Ft. long with Green Recycled Plastic 2" x 4" Slats.
Shown with optional engraved signage.

- **Extra heavy design to be stronger and more stable with a simple, clean design.**
- **Sturdy, formed and welded steel frame construction**
- **Frames are Hot-Dip Galvanized after fabrication for superior corrosion resistance**
- **100% Recycled Plastic seat and back planks with solid color and U.V. stabilizer for ultraviolet protection**
- **Precision drilled plastic planks**
- **Quality construction throughout**

SPECIFICATIONS:

- **Model PCXB** end frames are one-piece, welded construction with a back and seat bracket of 2-3/8" x 1-1/2" x 1/8" nominal sized, die-formed channel, and a 2.375" (2-3/8") O.D. post and foot to meet 2" nominal steel pipe size specifications. Frame foot is formed with flattened and rounded ends. A 9/16" hole is provided in each end of foot for optional surface mounting with concrete anchors (anchors not included).
- **Model PCXB/G-4** is 4 ft. long (nom.) with two frames.
- **Model PCXB/G-6** is 6 ft. long (nom.) with three frames.
- **Standard:** Frames are hot-dip galvanized after fabrication to ASTM-A123 to maintain an average zinc coating of 2.0 oz. per sq. ft. of surface area (indicated by "/G" in model no., e.g. PCXB/G-4PC24).
- **Standard:** Back and seat are made of 100% Recycled Plastic molded into 2" x 4" nominal sized planks with solid Cedar color (indicated by "PC" in model no., e.g. PCXB/G-4PC24) formed throughout and a U.V. stabilizer added for ultra-violet protection.
- All fasteners are provided for assembly.
- **Optional:** Color choices of powder coated steel frame components. For optional colors choices see Specification Bulletin #SPC-CO-001.
- **Optional:** Color choices of Recycled Plastic components. For optional colors choices see Specification Bulletin #SPC-CO-001.

AVAILABLE OPTIONS

- 4' or 6' models
- Powder Coat Finish in choice of colors for steel frame components
- Choice of colors of Recycled Plastic
- Routed Lettering available (call for details)
- Armrests

RJThomas Mfg. Co., Inc.

PO Box 946 • Cherokee, IA 51012-0946 • PH: 712-225-5115 • 800-762-5002 • FAX: 712-225-5796
E-mail: pilotrock@rjthomas.com • Web Site: <http://www.pilotrock.com>

© 2008 RJThomas Mfg. Co., Inc. PILOT ROCK® Park Products is a registered trademark of RJThomas Mfg. Co., Inc.

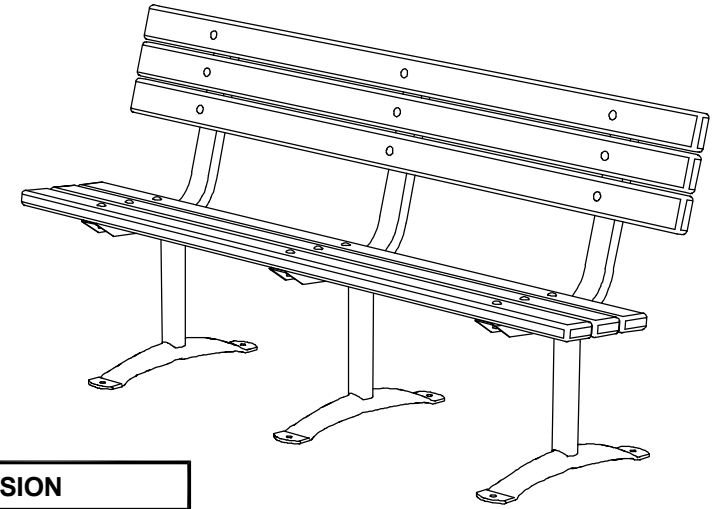
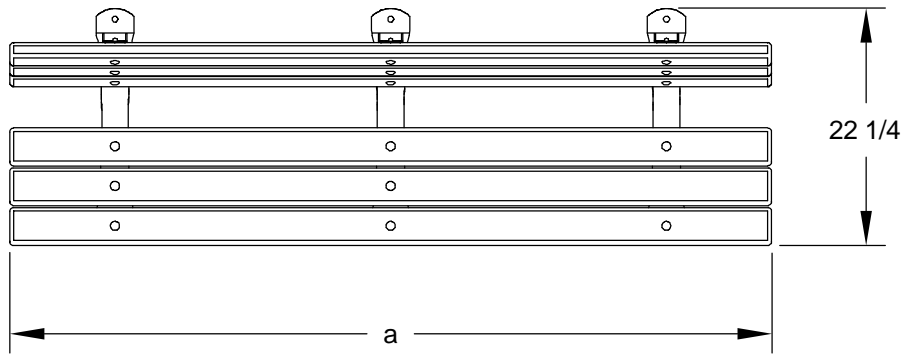

MODEL NUMBER	DIMENSION		
	a	b	c
PCXB-4	47-1/2	N/A*	36
PCXB3-6	71-1/2	25-7/8	51-3/4

* NOTE:
4 FT. LONG BENCH
USES TWO FRAMES
(DOES NOT HAVE
CENTER FRAME)

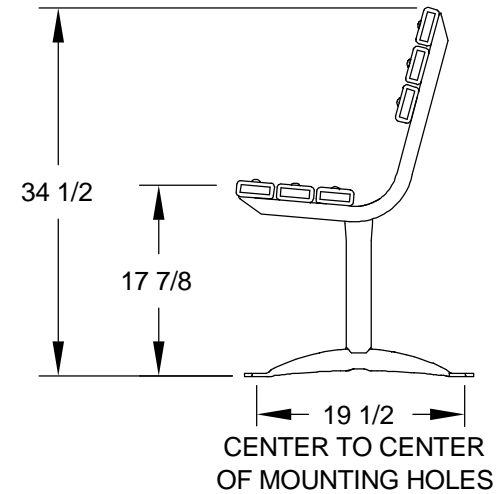
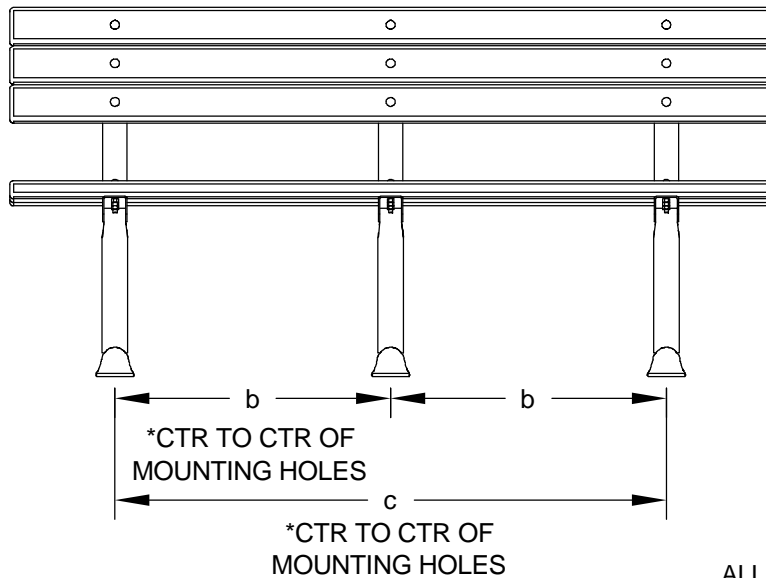

ALL DIMENSIONS IN INCHES

RJThomas Mfg. Co., Inc.
P.O. Box 946 • Cherokee, IA 51012-0946

DRAWN BY
WWM

TITLE MODEL PCXB EXTRA HEAVY DUTY 4 AND 6 FOOT SURFACE MOUNT/PORTABLE
BENCH WITH 2" X 4" RECYCLED PLASTIC PLANKS

DATE 9-03-08

DWG. NO. **AI-1631**