



*Model PCXB/G-6AL Surface Mount Bench
with Hot-Dip Galvanized Frames,
6 Ft. long with Aluminum seat and back.*

- **Extra heavy design to be stronger and more stable with a simple, clean style**
- **Sturdy, formed and welded steel frame construction**
- **Frames are Hot-Dip Galvanized after fabrication for superior corrosion resistance**
- **Structurally reinforced extruded Aluminum Seats with clear anodized finish**
- **Quality construction throughout**

SPECIFICATIONS:

- **Model PCXB** end frames are one-piece, welded construction with a back and seat bracket of 2-3/8" x 1-1/2" x 1/8" nominal sized, die-formed channel, and a 2.375" (2-3/8") O.D. post and foot to meet 2" nominal steel pipe size specifications. Frame foot is formed with flattened and rounded ends. A 9/16" hole is provided in each end of foot for optional surface mounting with concrete anchors (anchors not included).
- **Model PCXB/G-4** is 4 ft. long (nom.).
- **Model PCXB/G-6** is 6 ft. long (nom.) with diagonal braces.
- **Model PCXB/G-8** is 8 ft. long (nom.) with diagonal braces.
- **Standard:** All frame components are hot-dip galvanized after fabrication to ASTM-A123 to maintain an average zinc coating of 2.0 oz. per sq. ft. of surface area (indicated by "/G" in model no., e.g. PCXB/G-4AL).
- Aluminum is extruded 6063-T6 aluminum alloy in planks with dimensions equivalent to that of 2" x 10" nominal sized lumber. The plank design is 1-3/4" x 9-5/8" with four structural reinforcement ribs for greater rigidity. Aluminum planks are provided with a clear anodized finish as per anodizing specification 204 R1.
- Channel end caps of extruded 6063-T6 aluminum alloy are provided with a clear anodized finish as per anodizing specification 204 R1. End caps are press fitted over ends of aluminum planks and mechanically fastened in place at the factory.
- Aluminum planks are provided with galvanized carriage bolts and precision fitted aluminum brackets to fasten planks to bench frames.
- **Optional:** Color choices of powder coated steel frame components. For optional colors choices see Specification Bulletin # SPC-CO-001.
- **Optional:** Color choices of powder coated aluminum back and seat. For optional colors choices see Specification Bulletin # SPC-CO-001.

AVAILABLE OPTIONS

- **4', 6', or 8' models**
- **Powder Coat Finish in choice of colors for steel frame components**
- **Powder Coat Finish in choice of colors for aluminum seat and back**

RJThomas Mfg. Co., Inc.

PO Box 946 • Cherokee, IA 51012-0946 • PH: 712-225-5115 • 800-762-5002 • FAX: 712-225-5796
E-mail: pilotrock@rjthomas.com • Web Site: <http://www.pilotrock.com>

© 2008 RJThomas Mfg. Co., Inc. PILOT ROCK® Park Products is a registered trademark of RJThomas Mfg. Co., Inc.

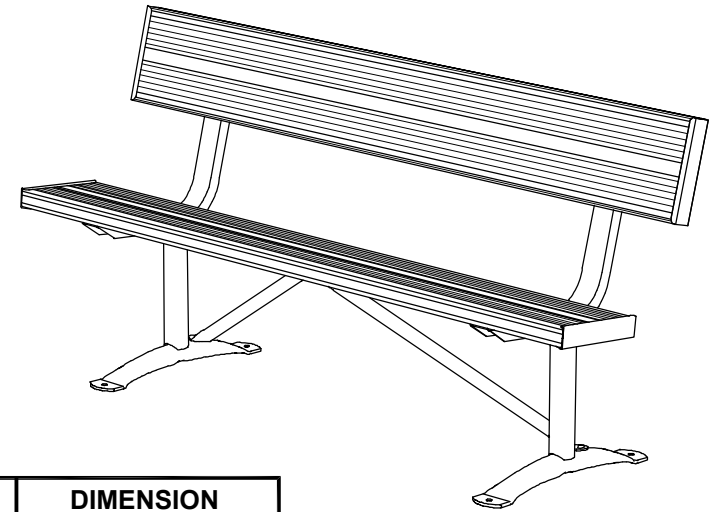
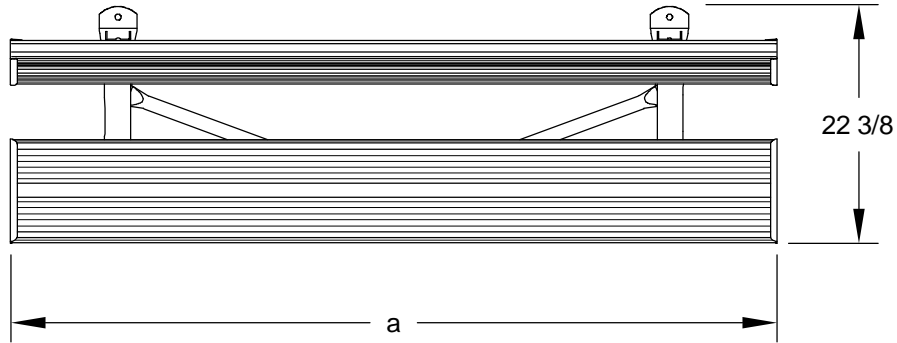

MODEL NUMBER	DIMENSION	
	a	b
PCXB-4	48	36
PCXB-6	72	51-3/4
PCXB-8	96	70

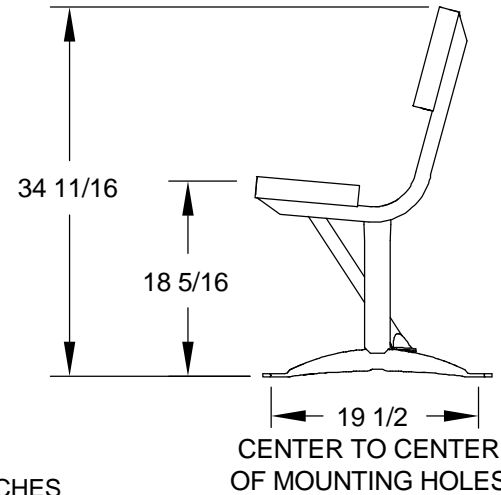
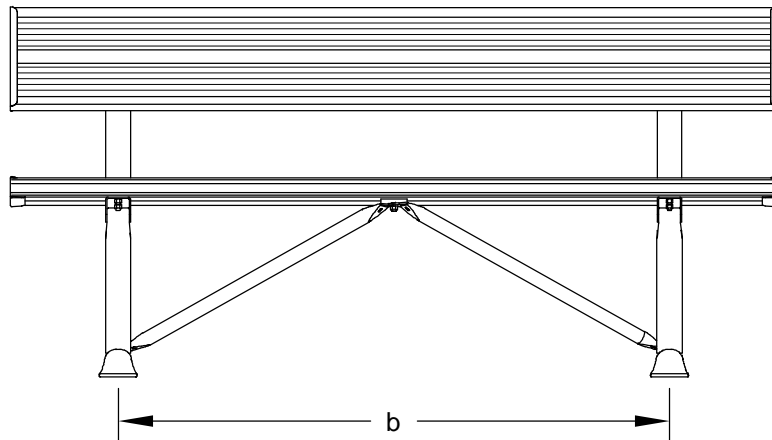

ALL DIMENSIONS IN INCHES

CENTER TO CENTER OF MOUNTING HOLES

RJThomas Mfg. Co., Inc.
P.O. Box 946 • Cherokee, IA 51012-0946

DRAWN BY
WWM

TITLE MODEL PCXB 4, 6, AND 8 FOOT PORTABLE/SURFACE MOUNT BENCH WITH 2" X 10" ALUMINUM SEAT AND BACK PLANKS

DATE 9-03-08

DWG. NO. AI-1640