

Model SWB 4, 6, and 8 Foot Embedded Mount Flat Bench with Lumber Timbers



*Model SWB/G-6TP 6 Ft. Embedded Mount Bench
with Hot Dip Galvanized Frames
and Pressure Treated Southern Yellow Pine 3" x 4" timbers.*

- **Sturdy welded steel construction**
- **Flat design with Bull-nosed outside timbers**
- **Pressure Treated Lumber resists decay**
- **Precision drilled 3" x 4" Timbers**
- **Quality construction throughout**

SPECIFICATIONS:

- **Model SWB Series** end frames are one-piece welded construction with 2-1/2" x 2-1/2" square steel post. Seat brackets are constructed of 3/8" x 4" A-36 flat steel bar to mount four 3" x 4" timbers.
- Bench is designed to be permanently anchored by embedding bench legs in concrete footings.
- **Model SWB-4** is a nom. 4 ft. in length.
- **Model SWB-6** is a nom. 6 ft. in length.
- **Model SWB-8** is a nom. 8 ft. in length.
- **Standard:** All steel frame components are hot-dip galvanized after fabrication to ASTM-A123 to maintain an average zinc coating of 2.0 oz. per sq. ft. of surface area (indicated by "/G" in model no., e.g. SWB/G-4TP).
- **Standard:** Lumber is #1 grade Southern Yellow Pine 3" x 4" nominal sized timbers pressure treated (KDAT) to preserve wood against decay (indicated by "TP" in model no., e.g. SWB/G-4TP). All lumber is surface planed on all four sides; precision drilled for assembly; and has all exposed edges removed to a 3/8" radius. Outside timbers have a bull-nose radius on outside edges.
- All fasteners are provided for assembly.
- **Optional:** Color choices of powder coated steel frame components. For optional colors choices see Specification Bulletin #SPC-CO-001.
- **Optional:** Construction Heart Redwood timbers are available. To specify, change "TP" in model no. to "CO", e.g. SWB/G-6CO. Other lumber species are available when in stock — please inquire.
- **Optional:** In lieu of carriage bolts, zinc plated lag screws are provided for timber connections – please specify when ordering.

AVAILABLE OPTIONS

- 4', 6', or 8' models
- Choice of colors of Powder Coat Finish on steel frame components
- Construction Heart Redwood lumber
- Armrests

RJThomas Mfg. Co., Inc.

PO Box 946 • Cherokee, IA 51012-0946 • PH: 712-225-5115 • 800-762-5002 • FAX: 712-225-5796
E-mail: pilotrock@rjthomas.com • Web Site: <http://www.pilotrock.com>

© 2008 RJThomas Mfg. Co., Inc. PILOT ROCK® Park Products is a registered trademark of RJThomas Mfg. Co., Inc.

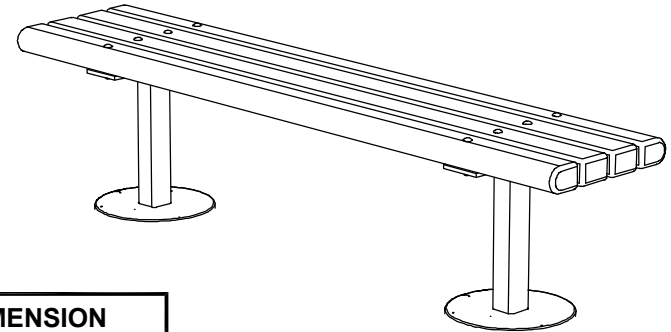

MODEL NUMBER	DIMENSION	
	a	b
SWB-4	47-1/2	36
SWB-6	71-1/2	48
SWB-8	95-1/2	68

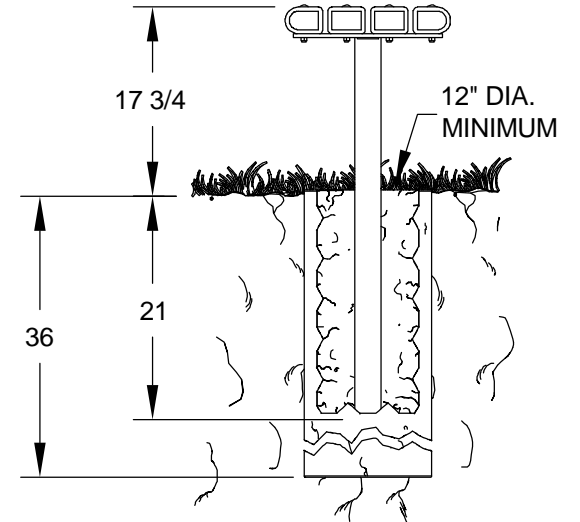
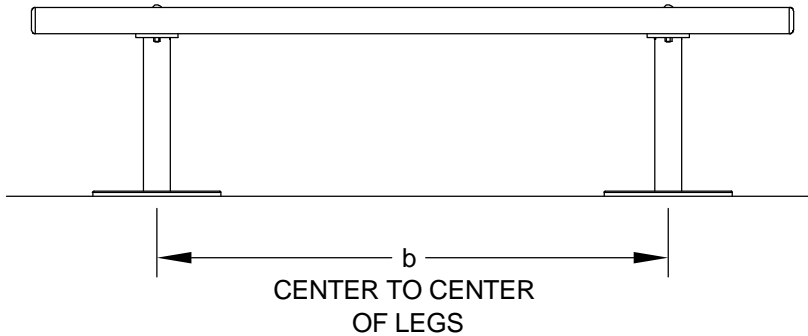

NOTE:
LOCAL SOIL
CONDITIONS
MAY REQUIRE
A LARGER
FOOTING
(CHECK LOCAL
CODES)

ALL DIMENSIONS IN INCHES

RJThomas Mfg. Co., Inc.
P.O. Box 946 • Cherokee, IA 51012-0946

DRAWN BY
WWM

TITLE MODEL SWB 4, 6, AND 8 FOOT EMBEDDED MOUNT FLAT BENCH
WITH 3" X 4" LUMBER TIMBERS

DATE 9-04-08

DWG. NO. **AI-1652**