

Model PWB 4, 6, and 8 Foot Portable or Surface Mount Flat Bench with Recycled Plastic Timbers



*Model PWB/CB-6PD34 6 Ft. Surface Mount Bench
with black powder coated frames
and weathered redwood colored recycled plastic 3" x 4" timbers.*

- **Sturdy, formed and welded steel construction**
- **Flat design with Bull-nosed outside timbers**
- **100% Recycled Plastic seat timbers with solid color and U.V. stabilizer for ultraviolet protection**
- **Precision drilled plastic timbers**
- **Quality construction throughout**

SPECIFICATIONS:

- **Model PWB Series** end frames are one-piece welded construction with 2-1/2" x 2-1/2" square steel post. Seat brackets are constructed of 3/8" x 4" A-36 flat steel bar, die-formed for shape and reinforcement, to mount four 3" x 4" timbers. A welded-on foot of formed 3/8" x 4" A-36 flat steel bar provides two 25/32" holes for anchoring to hard surfaces (anchor bolts not included).
- **Model PWB-4** is a nom. 4 ft. in length with two (2) frames.
- **Model PWB3-6** is a nom. 6 ft. in length with three (3) frames.
- **Model PWB3-8** is a nom. 8 ft. in length with three (3) frames.
- **Standard:** All steel frame components are hot-dip galvanized after fabrication to ASTM-A123 to maintain an average zinc coating of 2.0 oz. per sq. ft. of surface area (indicated by "/G" in model no., e.g. PWB/G-4PC34).
- **Standard:** Seat is made of 100% Recycled Plastic molded into 3" x 4" nominal sized timbers with solid Cedar color (indicated by "PC" in model no., e.g. PWB/G-4PC34) formed throughout and a U.V. stabilizer added for ultra-violet protection.
- All fasteners are provided for assembly.
- **Optional:** Color choices of powder coated steel frame components. For optional colors choices see Specification Bulletin #SPC-CO-001.
- **Optional:** Color choices of Recycled Plastic components. For optional colors choices see Specification Bulletin #SPC-CO-001.
- **Optional:** In lieu of carriage bolts, zinc plated lag screws shall be provided for timber connections – please specify when ordering.

AVAILABLE OPTIONS

- **4', 6', or 8' models**
- **Choice of colors of Powder Coat Finish on steel frame components**
- **Choice of colors of Recycled Plastic**
- **Armrests**

RJ Thomas Mfg. Co., Inc.

PO Box 946 • Cherokee, IA 51012-0946 • PH: 712-225-5115 • 800-762-5002 • FAX: 712-225-5796
E-mail: pilotrock@rjthomas.com • Web Site: <http://www.pilotrock.com>

© 2008 RJ Thomas Mfg. Co., Inc. PILOT ROCK® Park Products is a registered trademark of RJ Thomas Mfg. Co., Inc.

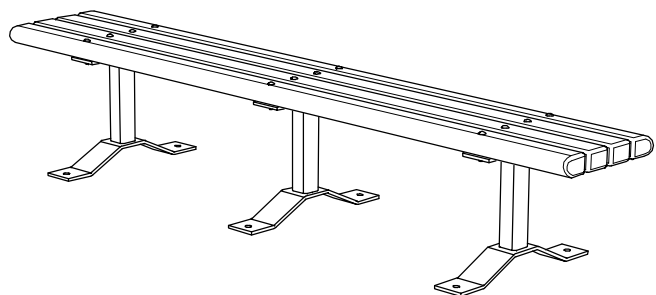
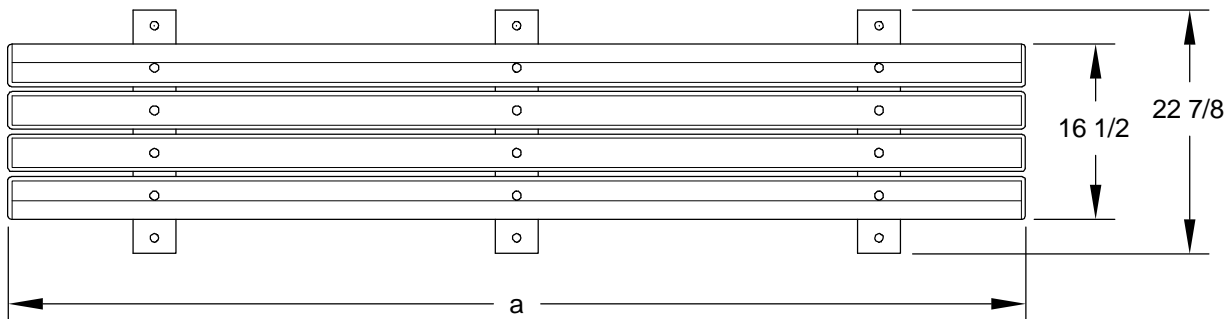

MODEL NUMBER	DIMENSION		
	a	b	c
PWB-4	47-1/2	N/A	36
PWB3-6	71-1/2	24	48
PWB3-8	95-1/2	34	68

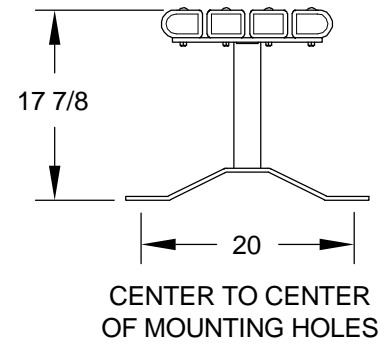
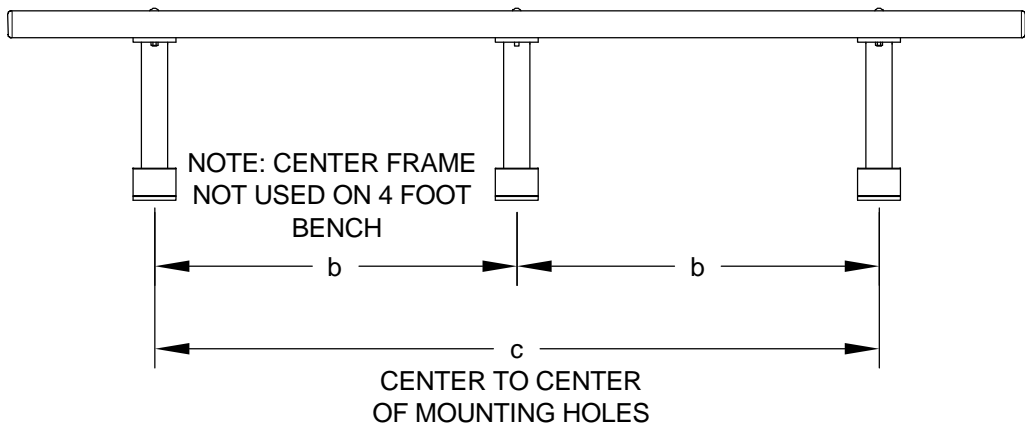

ALL DIMENSIONS IN INCHES

ALL DIMENSIONS IN INCHES

RJThomas Mfg. Co., Inc.
P.O. Box 946 • Cherokee, IA 51012-0946

DRAWN BY
WWM

TITLE MODEL PWB 4, 6, AND 8 FOOT PORTABLE/SURFACE MOUNT FLAT BENCH
WITH 3" X 4" RECYCLED PLASTIC TIMBERS

DATE 4-21-10

DWG. NO. **AI-1653**