



*Model B82/CN-4IB34 Surface Mount Bench
with Green Powder Coat Frames, 4 Ft. long
with Indonesian Balau Wood seat timbers.*

- **Comfortable contour seat design**
- **Frame curves form comfortable armrests**
- **Sturdy cast iron end frames. Formed and welded steel seat and brace components**
- **Powder Coat frame finish**
- **Indonesian Balau Wood 3" x 4" Timbers**
- **Easy bolt together assembly**
- **Quality construction throughout**

SPECIFICATIONS:

- **Model B82 Series** end frames are a one-piece molded cast iron construction with a circular armrest incorporated into the design.
- Frames are supported by a horizontal brace of 1.9" O.D. x 11 ga. wall steel pipe.
- 6 and 8 foot models include a center vertical support that connects all seat timbers and the horizontal brace to prevent deflection of timbers.
- Bench is designed to be permanently surface mounted using 9/16" dia. holes provided in each leg foot for use with anchors (anchors not included).
- **Model B82-4** is a nom. 4 ft. in length.
- **Model B82-6** is a nom. 6 ft. in length.
- **Model B82-8** is a nom. 8 ft. in length.
- Seat timbers attach to end frame by means of a 7 ga. formed and welded steel bracket.
- **Standard:** All steel and cast iron frame components are finished in Black powder coat (indicated by "/CB" in model no., e.g. B82/CB-4IB34).
- **Standard:** Lumber is Indonesian Balau Wood 3" x 4" nominal sized timbers (indicated by "IB" in model no., e.g. B82/CB-4IB34). All timbers are precision drilled for assembly and have all exposed edges removed to a 3/8" radius with a bullnose profile timber used on outside positions.
- All fasteners are provided for assembly.
- **Optional:** Color choices of powder coated frame components. For optional colors choices see Specification Bulletin #SPC-CO-001.

AVAILABLE OPTIONS

- **4', 6', or 8' models**
- **Choice of colors of Powder Coat Finish on frame components**

RJThomas Mfg. Co., Inc.

PO Box 946 • Cherokee, IA 51012-0946 • PH: 712-225-5115 • 800-762-5002 • FAX: 712-225-5796
E-mail: pilotrock@rjthomas.com • Web Site: <http://www.pilotrock.com>

© 2008 RJThomas Mfg. Co., Inc. PILOT ROCK® Park Products is a registered trademark of RJThomas Mfg. Co., Inc.

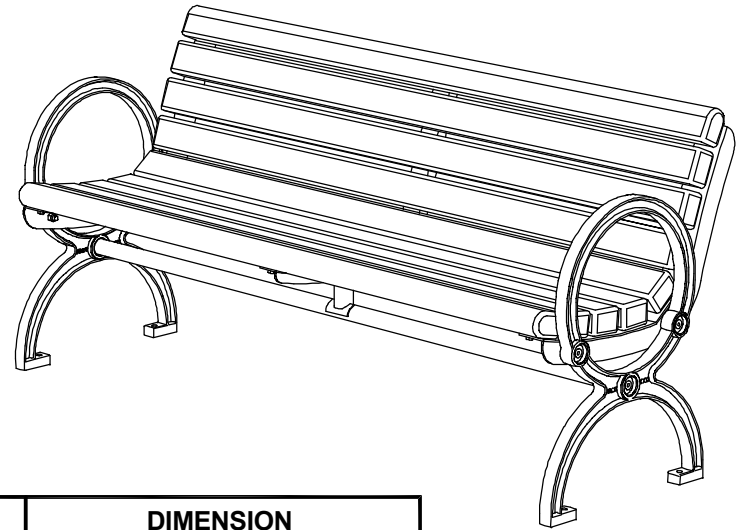
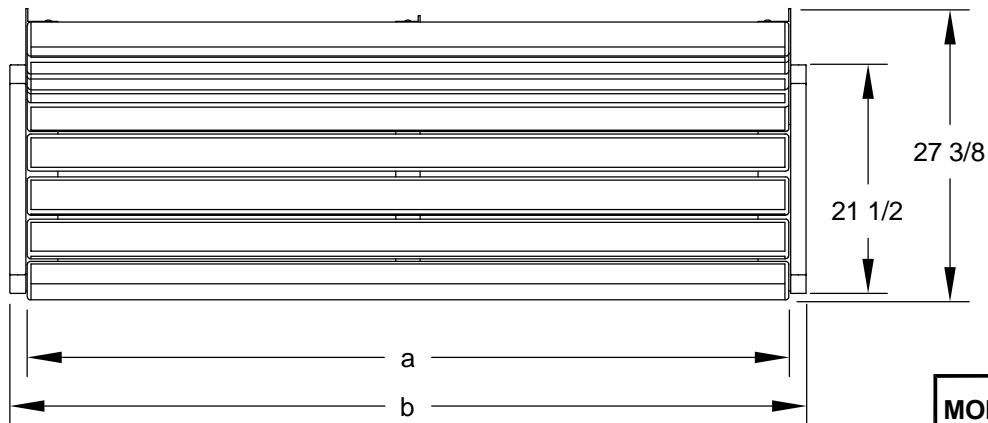

MODEL NUMBER	DIMENSION		
	a	b	c
B82-4	47 1/2	50 3/4	49 1/2
B82-6	71 1/2	74 3/4	73 1/4
B82-8	95 1/2	98 3/4	97 1/4

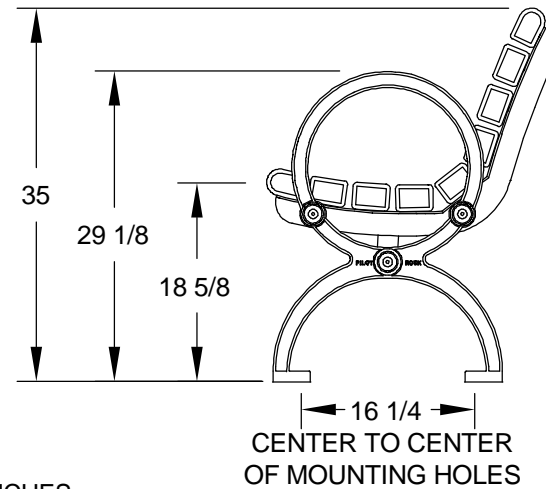
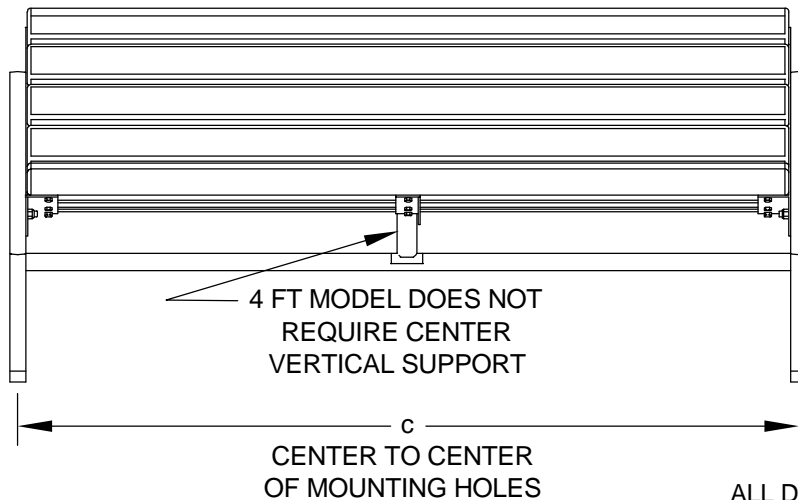

ALL DIMENSIONS IN INCHES

RJThomas Mfg. Co., Inc.
P.O. Box 946 • Cherokee, IA 51012-0946

DRAWN BY
WWM

TITLE GILLETTE SERIES MODEL B82 4, 6, AND 8 FOOT CONTOUR SURFACE MOUNT BENCH WITH CAST IRON END FRAMES AND 3" X 4" LUMBER SEAT AND BACK TIMBERS

DATE 9-02-08

DWG. NO. **AI-1735**