



*Model B80/CN-6SP Surface Mount Flat Bench  
with Green Powder Coat Finish, 6 Ft. long.*

- **Comfortable decoratively cut steel plate flat seat design**
- **Frame curves form comfortable armrests**
- **Sturdy cast iron end frames. Formed and welded steel seat and brace components**
- **Powder Coat finish**
- **Easy bolt together assembly**
- **Quality construction throughout**

---

#### **SPECIFICATIONS:**

---

- **Model B80 Series** end frames are a one-piece molded cast iron construction with a circular armrest incorporated into the design.
- Frames are supported by a horizontal brace of 1.9" O.D. x 11 ga. wall steel pipe.
- 6 and 8 foot models include a center vertical support that connects all seat timbers and the horizontal brace to prevent deflection of timbers.
- Bench is designed to be permanently surface mounted using 9/16" dia. holes provided in each leg foot for use with anchors (anchors not included).
- **Model B80-4** is a nom. 4 ft. in length.
- **Model B80-6** is a nom. 6 ft. in length.
- **Model B80-8** is a nom. 8 ft. in length.
- **Standard:** Seat is a one piece assembly made of a decorative horizontal diamond pattern cut into a 10 ga. thick steel plate welded to 7 ga. end plates. Seat edges have a 1-13/16" radius roll to form a smooth curved outer edge of seat.
- **Standard:** All steel and cast iron frame components are finished in Black powder coat (indicated by "/CB" in model no., e.g. B80/CB-6SP).
- All fasteners are provided for assembly.
- **Optional:** Color choices of powder coated finish. For optional colors choices see Specification Bulletin #SPC-CO-001.
- **Optional:** Custom lettering cut into the seat area is available, please inquire for details.

---

#### **AVAILABLE OPTIONS**

---

- **4', 6', or 8' models**
- **Choice of colors of Powder Coat Finish**
- **Custom lettering cut into seat**

**RJThomas Mfg. Co., Inc.**

PO Box 946 • Cherokee, IA 51012-0946 • PH: 712-225-5115 • 800-762-5002 • FAX: 712-225-5796  
E-mail: pilotrock@rjthomas.com • Web Site: <http://www.pilotrock.com>

© 2008 RJThomas Mfg. Co., Inc. PILOT ROCK® Park Products is a registered trademark of RJThomas Mfg. Co., Inc.

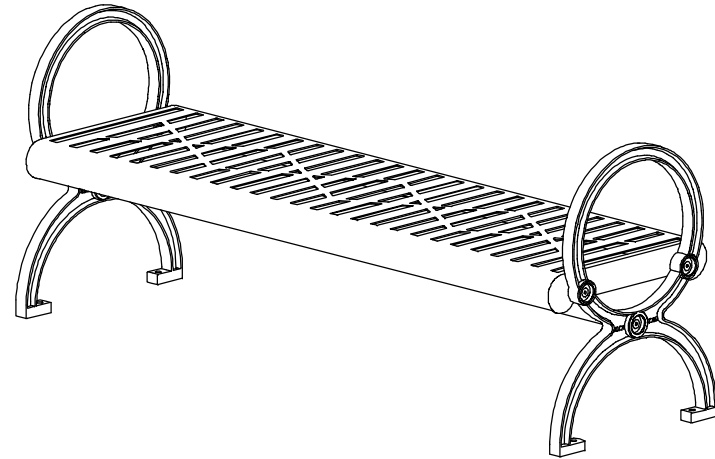
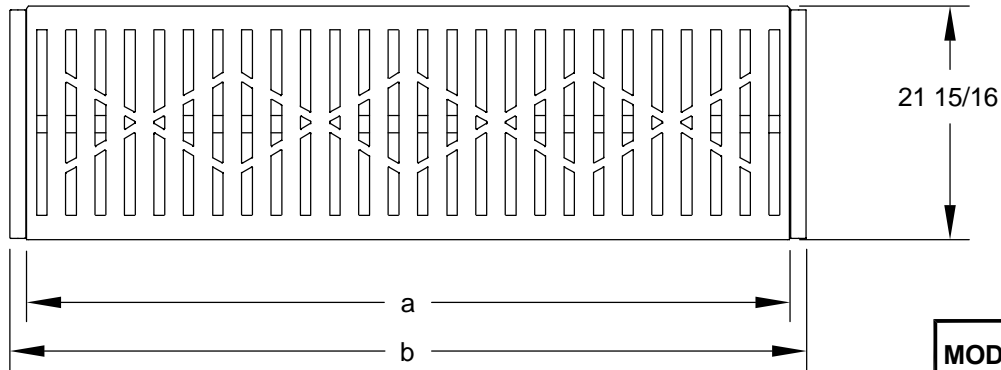

MODEL NUMBER	DIMENSION		
	a	b	c
B80-4	47 1/2	50 3/4	49 1/2
B80-6	71 1/2	74 3/4	73 1/4
B80-8	95 1/2	98 3/4	97 1/4

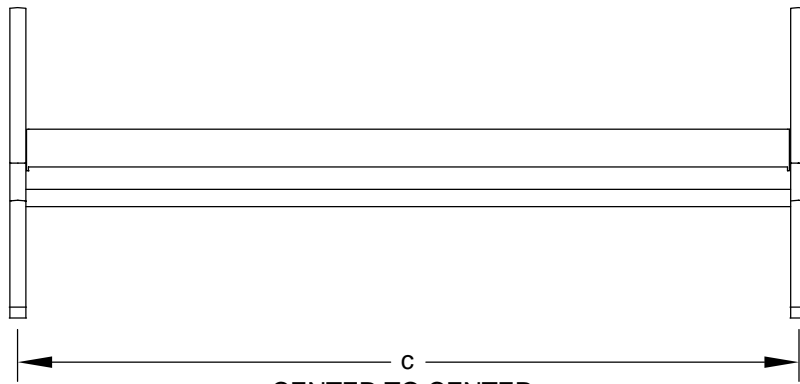

CENTER TO CENTER  
OF MOUNTING HOLES

ALL DIMENSIONS IN INCHES

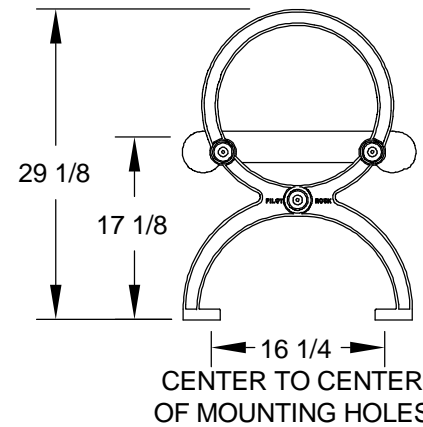

**RJThomas Mfg. Co., Inc.**  
P.O. Box 946 • Cherokee, IA 51012-0946

DRAWN BY  
**WWM**

TITLE GILLETTE SERIES MODEL B80 4, 6, AND 8 FOOT FLAT SURFACE MOUNT BENCH  
WITH CAST IRON END FRAMES AND STEEL PLATE SEAT

DATE 9-02-08

DWG. NO. **AI-1808**