



*Model B90/CW-6SP Surface Mount Flat Bench
with Brown Powder Coat finish, 6 Ft. long.*

- **Comfortable flat seat design**
- **Frame design includes comfortable armrests**
- **Sturdy cast iron end frames. Formed and welded steel seat and brace components**
- **Powder Coat finish**
- **Easy bolt together assembly**
- **Quality construction throughout**

SPECIFICATIONS:

- **Model B90** end frames are one-piece molded cast iron construction.
- Frames are supported by a horizontal brace of 1.9" O.D. x 11 ga. wall steel pipe.
- Bench is designed to be permanently surface mounted using 9/16" dia. holes provided in each leg foot for use with anchors (anchors not included).
- **Model B90-4** is a nom. 4 ft. in length.
- **Model B90-6** is a nom. 6 ft. in length.
- **Model B90-8** is a nom. 8 ft. in length.
- **Standard:** Seat is a one piece assembly made of a decorative horizontal diamond pattern cut into a 10 ga. thick steel plate welded to 7 ga. end plates. Seat edges have a 1-13/16" radius roll to form a smooth curved outer edge of seat.
- **Standard:** All steel and cast iron frame components are finished in Black powder coat (indicated by "/CB" in model no., e.g. B90/CB-6SP).
- All fasteners are provided for assembly.
- **Optional:** Color choices of powder coated finish. For optional colors choices see Specification Bulletin #SPC-CO-001.
- **Optional:** Custom lettering cut into the seat area is available, please inquire for details.

AVAILABLE OPTIONS

- 4', 6', or 8' models
- Choice of colors of Powder Coat Finish
- Custom lettering cut into seat

RJThomas Mfg. Co., Inc.

PO Box 946 • Cherokee, IA 51012-0946 • PH: 712-225-5115 • 800-762-5002 • FAX: 712-225-5796
E-mail: pilotrock@rjthomas.com • Web Site: <http://www.pilotrock.com>

© 2008 RJThomas Mfg. Co., Inc. PILOT ROCK® Park Products is a registered trademark of RJThomas Mfg. Co., Inc.

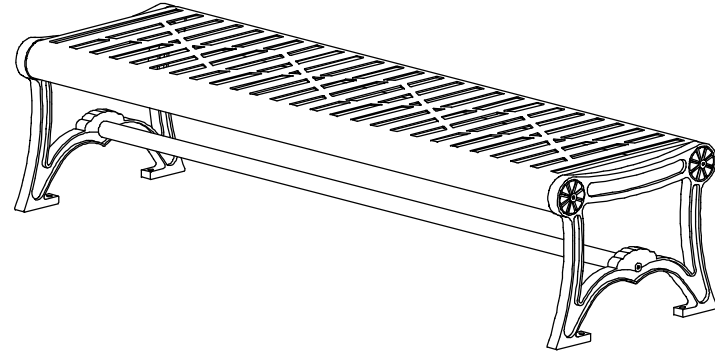
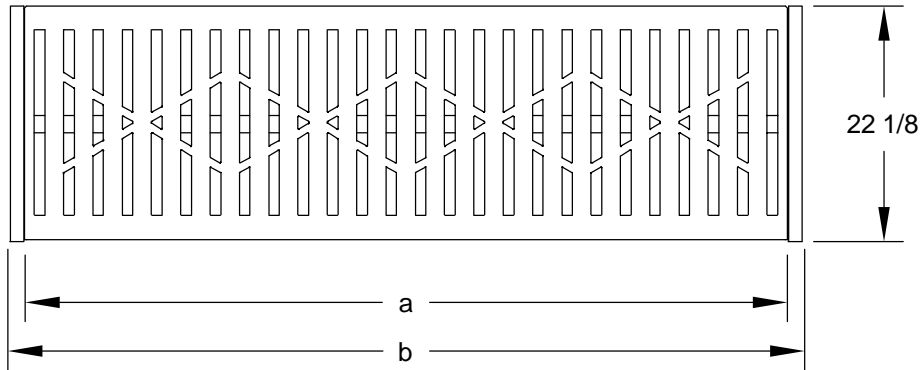

MODEL NUMBER	DIMENSION		
	a	b	c
B90-4	47 1/2	50 1/4	49
B90-6	71 1/2	74 1/4	73
B90-8	95 1/2	98 1/4	97

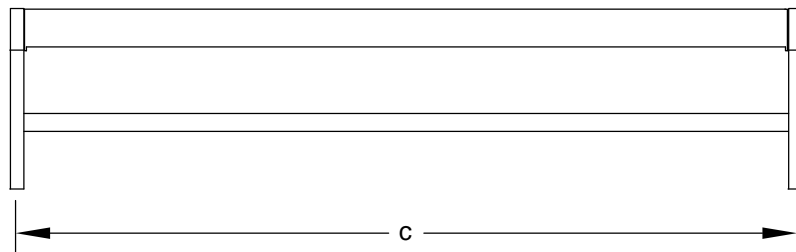

CENTER TO CENTER
OF MOUNTING HOLES

ALL DIMENSIONS IN INCHES

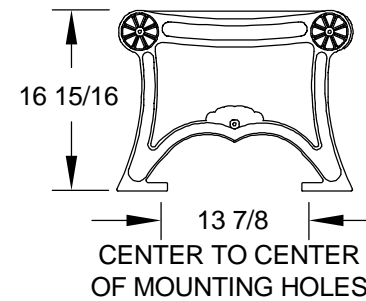

RJThomas Mfg. Co., Inc.
P.O. Box 946 • Cherokee, IA 51012-0946

DRAWN BY
WWM

TITLE OAK KNOLL SERIES MODEL B90 4, 6, AND 8 FOOT FLAT SURFACE MOUNT BENCH
WITH CAST IRON END FRAMES AND STEEL PLATE SEAT

DATE 9-02-08

DWG. NO. **AI-1810**