

# FS-30 Series Campfire Ring with Tip-back Anchors



*Model FS-30/7/TB Campfire Ring*

- **Flanged firering for strength and safety**
- **Single level, hinged cooking grate**
- **Grate tips back for fire building**
- **Public use-type spring grips of coiled steel bar**
- **Three fire barrier heights available**
- **Firering tips back for easy cleaning**
- **Tip-back anchors embedded in concrete footings provide permanent location**
- **“Bottomless” design installs without concrete pad**
- **Utility shelf option**
- **Quality construction throughout**

## **SPECIFICATIONS:**

- **Model FS-30/7/TB** has a 7-3/8" high fire barrier. 32" overall dia. ring is constructed from 3/16" thick steel with a formed (NOT WELDED) 1" flanged lip around the top of the ring and 9/16" dia. draft holes spaced around the bottom perimeter.
- **Model FS-30/9/TB** has a 9" high fire barrier. 32" overall dia. ring is constructed from 3/16" thick steel with a formed (NOT WELDED) 1" flanged lip around the top of the ring and 1" dia. draft holes spaced around the bottom perimeter.
- **Model FS-30/11/TB** has an 11-3/8" high fire barrier. 32" overall dia. ring is constructed from 3/16" thick steel with a formed (NOT WELDED) 1" flanged lip around the top of the ring and 1" dia. draft holes spaced around the bottom perimeter.
- 290 sq. in. grate is constructed from 5/8" dia. A-36 steel bars around the perimeter, 3/4" dia. A-36 steel bar for the handle and 1/2" dia. A-36 steel bars to provide the grate surface.
- Grate is attached to and hinge upon 2 tightly formed eyelets made from 5/8" dia. A-36 steel bar that make a mechanically secure theft-proof attachment.
- Grate tips over backward to allow unobstructed viewing of the fire by persons seated around the fire. Grate is supported by the ground when tipped back so grate cannot be vandalized.
- Grate handle is provided with two substantially constructed spring grips suitable for public use made from 1/8" x 1/2" steel flat bar.
- Ring is provided with hinged anchoring device to allow ring to tip upward for easy cleaning. Two 1/2" dia. steel "U" anchor pins with deformed ends insert 15" into concrete footings (indicated by /TB in model no., e.g. FS-30/7/TB).
- Entire unit is finished in high temperature, heat resistant, nontoxic black enamel paint.
- **Optional:** Firering shall be provided with a 3/16" x 7-1/8" x 9-5/8" steel plate utility shelf. (Add /S to model no., e.g. FS-30/7/TB/S.)

## **AVAILABLE OPTIONS**

**Utility Shelf**

**RJThomas Mfg. Co., Inc.**

PO Box 946 • Cherokee, IA 51012-0946 • PH: 712-225-5115 • 800-762-5002 • FAX: 712-225-5796  
E-mail: [pilotrock@rjthomas.com](mailto:pilotrock@rjthomas.com) • Web Site: <http://www.pilotrock.com>

© 2008 RJThomas Mfg. Co., Inc. PILOT ROCK® Park Products is a registered trademark of RJThomas Mfg. Co., Inc.

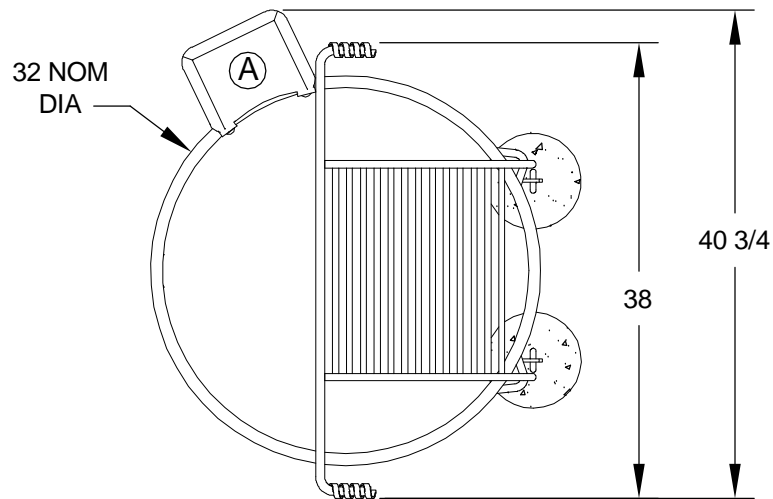

MODEL  
FS-30/11/TB  
- SHOWN IN TIP-BACK  
POSITION FOR  
CLEANING

MODEL  
FS-30/9/TB

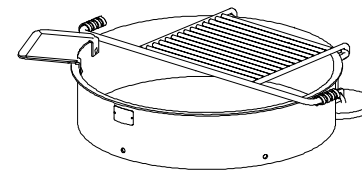
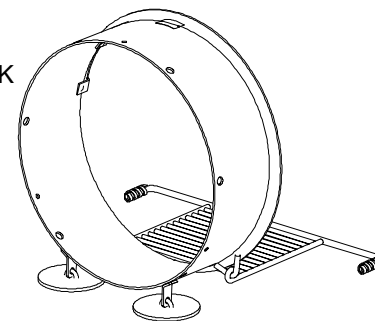
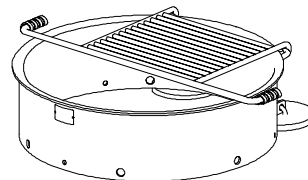

MODEL  
FS-30/7/TB/S

(A) OPTIONAL UTILITY SHELF - ADD /S  
TO MODEL NUMBER

MODEL NUMBER	DIMENSION	
	a	b
FS-30/7/TB	7-3/8	8
FS-30/9/TB	9	9-5/8
FS-30/11/TB	11-3/8	12

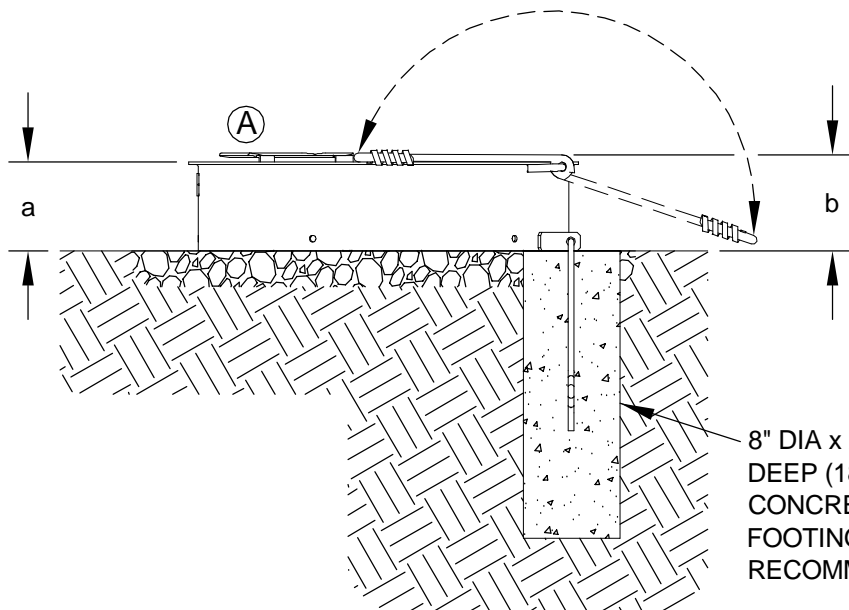

8" DIA x 24"  
DEEP (18" MIN)  
CONCRETE  
FOOTING  
RECOMMENDED

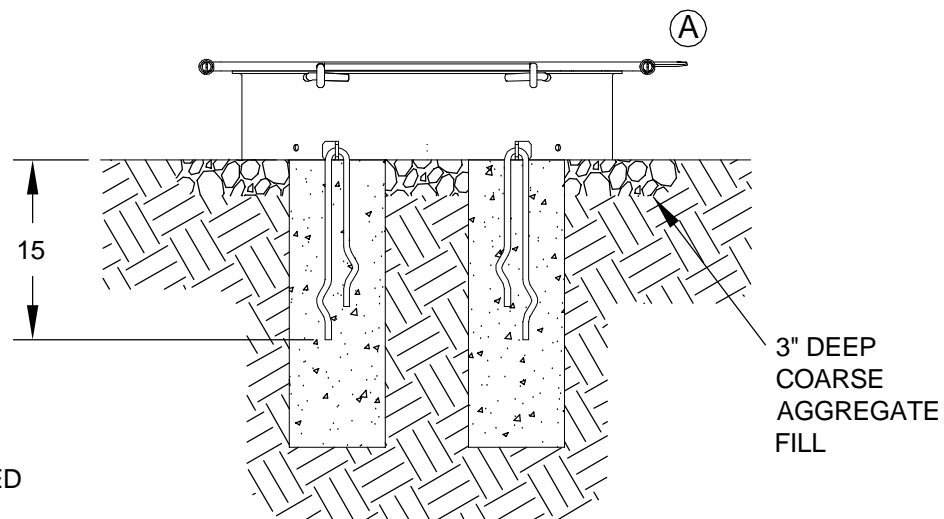

3" DEEP  
COARSE  
AGGREGATE  
FILL

ALL DIMENSIONS IN INCHES

**RJThomas Mfg. Co., Inc.**  
P.O. Box 946 • Cherokee, IA 51012-0946

DRAWN BY  
**WWM**

TITLE FS-30 SERIES TIP-BACK CAMPFIRE RING; 3 MODELS WITH 3 SIDE HEIGHTS  
-SHOWN WITH OPTIONAL UTILITY SHELF

DATE 9-17-08

DWG. NO. AI-1428