

# Model O-34 Large Group Firering



*Model O-34/TB Large Group Firering*

- **510 square inches of cooking surface**
- **Cooking grate tips back for easy fire building and cleaning**
- **Public use-type spring grips of coiled steel bar**
- **No leveraged pinch points between grate and ring**
- **Choice of large open fire or small fire under grate for cooking**
- **Firering tips back for easy cleaning**
- **Tip-back anchors embedded in concrete footings provide permanent location**
- **Quality construction throughout**

## **SPECIFICATIONS:**

- **Model O-34** firering is 34" x 40" with a 6" high fire barrier constructed of 1/4" plate steel and cross braced with 1-1/4" x 1-1/4" x 3/16" A-36 steel angle.
- Unit is permanently installed and tips upward for easy cleaning on hinged anchor devices with two 1/2" dia. steel "U" anchor pins with deformed ends that insert 15" into concrete footings.
- 510 sq. in. grate is 9" above ground level and is constructed from 1/2" dia. A-36 steel rods spaced 1-1/8" on centers and held securely in heat expansion channels to allow rods to expand under heat. Grate perimeter is constructed of 1/4" x 3" steel flat bar on the front and 1/4" x 2" steel flat bar on the sides and rear and is permanently attached and hinged at rear to tip back.
- Grill design provides 1" gap on sides to eliminate leveraged pinch point as grate closes on firebox.
- Grate is provided with two substantially constructed coil spring grips suitable for public use made from 1/8" x 1/2" flat steel bar (not wire springs).
- Entire unit is finished in high temperature, heat resistant, nontoxic black enamel.
- **Optional:** Ring is provided with two heavy anchors of 1-3/4" x 1-3/4" x 3/16" A-36 steel angle with welded-on spades of 1/8" thick steel and a 1/2" dia. A-36 steel rod to anchor unit to ground without concrete footings and allow tipping back for cleaning (indicated by /TA in model no., e.g. O-34/TA).

## **AVAILABLE OPTIONS**

**Tip-back angle spade anchors**

**RJThomas Mfg. Co., Inc.**

PO Box 946 • Cherokee, IA 51012-0946 • PH: 712-225-5115 • 800-762-5002 • FAX: 712-225-5796  
E-mail: pilotrock@rjthomas.com • Web Site: <http://www.pilotrock.com>

© 2008 RJThomas Mfg. Co., Inc. PILOT ROCK® Park Products is a registered trademark of RJThomas Mfg. Co., Inc.

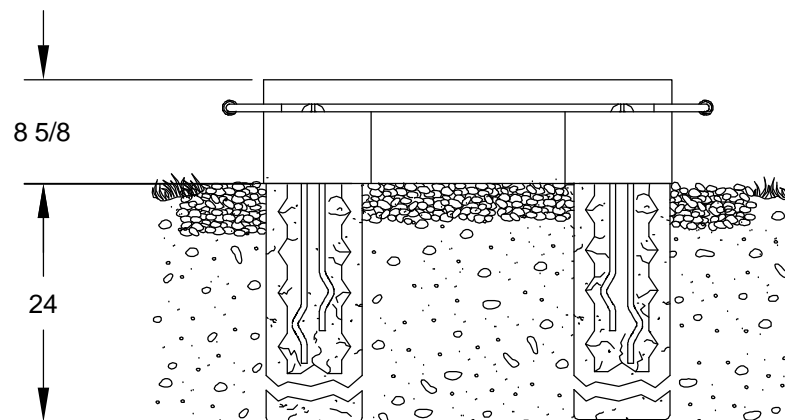
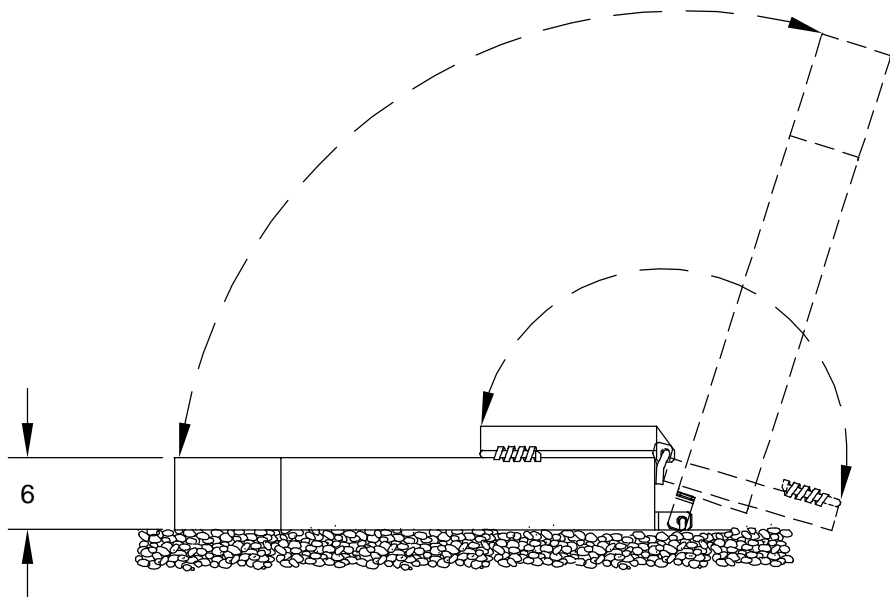
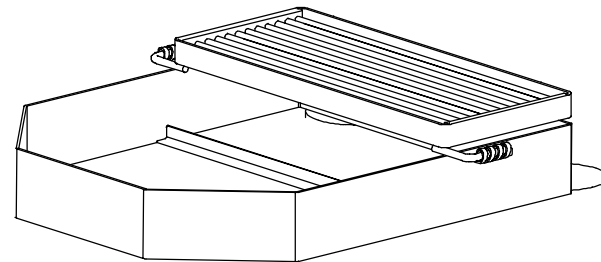
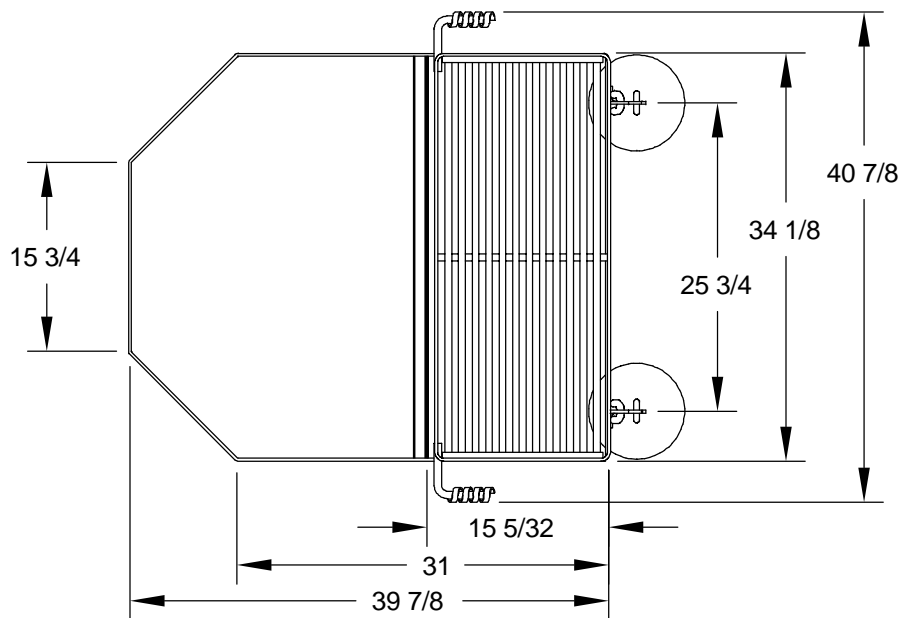

ALL DIMENSIONS IN INCHES

**RJThomas Mfg. Co., Inc.**  
P.O. Box 946 • Cherokee, IA 51012-0946

DRAWN BY  
**WWM**

TITLE **MODEL O-34 LARGE GROUP FIRERING WITH TIP BACK ANCHORS**

DATE **10-06-08**

DWG. NO. **AI-1755**