



Model FS/DW-30/18/TB Wheelchair Accessible Campfire Ring

- **Flanged outer firering for strength and safety**
- **Cooling air gap between rings keeps outer ring cool**
- **Inner ring supports fire grate**
- **Single level, hinged cooking grate**
- **Grate swings outside of ring when not in use for better access to the fire and an open camp fire effect**
- **Public use-type spring grips of coiled steel bar**
- **Elevated cooking grate and firebed conform to ADA guidelines**
- **Quality construction throughout**

SPECIFICATIONS:

- **Model FS/DW-30/18/TB** has a 32" overall dia. outer ring constructed from 1/8" thick steel with a formed (NOT WELDED) 1" flanged lip at top of ring and ten 1" dia. draft holes located around the perimeter. Firering side is 17-3/8" tall. Ring is provided with hinged anchoring device to allow ring to tip upward for easy cleaning. Two 1/2" dia. steel "U" anchor pins with deformed ends insert 15" into concrete footings.
- Inner fire wall is constructed from 3/16" steel formed in a nominal 26-3/8" dia. ring welded to outer ring by means of three 2-1/2" x 2-1/2", full length steel angles. Ten 1" dia. draft holes are provided in the 17-3/8" tall inner wall.
- 370 sq. in. cooking grate is constructed from 5/8" dia. A-36 steel bar around the perimeter, 3/4" A-36 steel bar for the handle, and 1/2" dia. A-36 steel bar for the grate bars. Grate is attached to and hinged upon 2 tightly formed eyelets made from 5/8" dia. A-36 steel bar that make a mechanically secure theft-proof attachment.
- Grate handles are provided on the cooking grate with two substantially constructed spring grips suitable for public use made from 1/8" x 1/2" steel flat bar.
- 380 sq. in. log grate area is constructed from 5/8" dia. A-36 steel bar around the perimeter and 1/2" dia. A-36 steel bar for the grate bars. Grate is permanently attached and hinged by means of 2 tightly formed eyelets made from 5/8" dia. A-36 steel bar at one end and supported by 2 supports made from formed 5/8" dia. A-36 steel bar at the opposite end. Grate lifts opposite the cooking grate for easy cleanout.
- Entire unit is finished in high temperature, heat resistant, nontoxic black enamel.

RJThomas Mfg. Co., Inc.

PO Box 946 • Cherokee, IA 51012-0946 • PH: 712-225-5115 • 800-762-5002 • FAX: 712-225-5796
E-mail: pilotrock@rjthomas.com • Web Site: <http://www.pilotrock.com>

© 2008 RJThomas Mfg. Co., Inc. PILOT ROCK® Park Products is a registered trademark of RJThomas Mfg. Co., Inc.

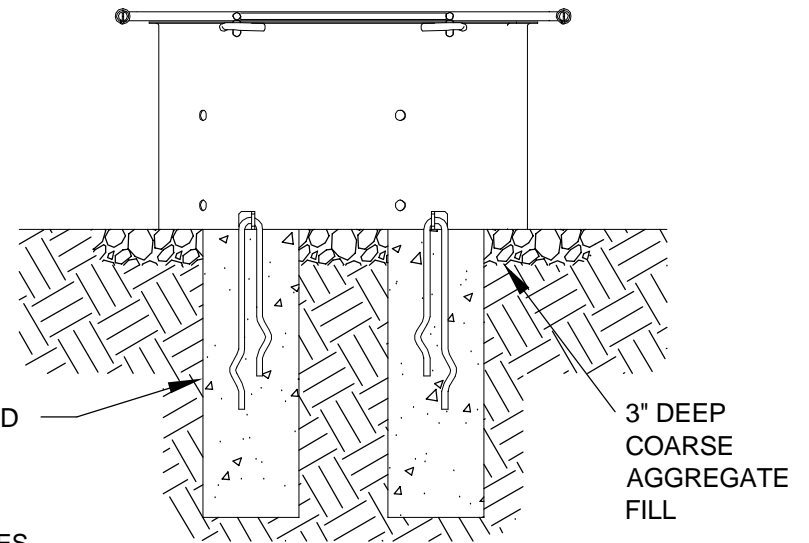
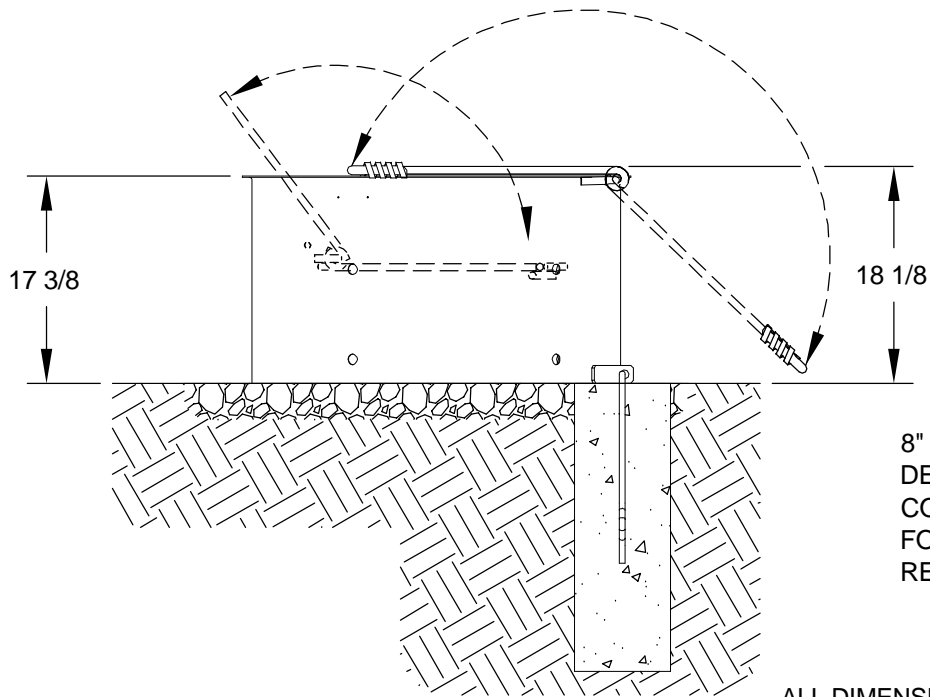
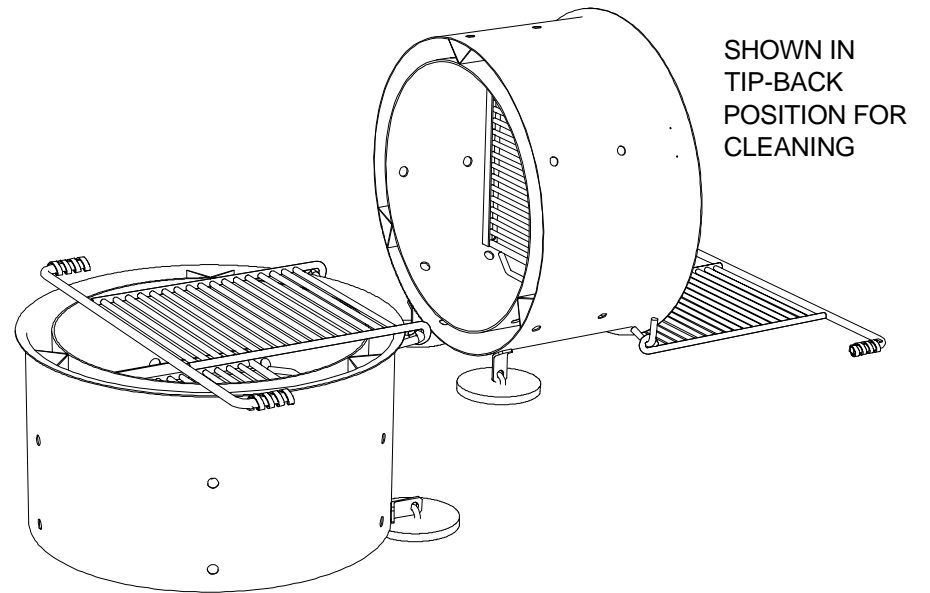
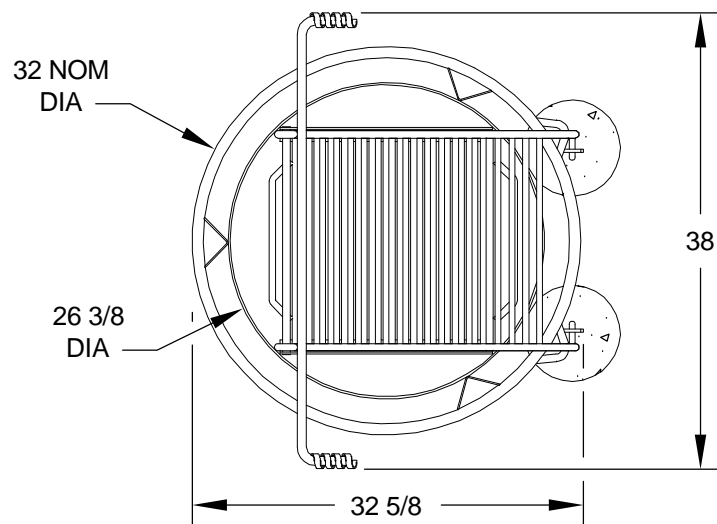

ALL DIMENSIONS IN INCHES

RJThomas Mfg. Co., Inc.
P.O. Box 946 • Cherokee, IA 51012-0946

DRAWN BY
MGB

TITLE **FS/DW-30/18/TB WHEELCHAIR ACCESSIBLE DOUBLE WALLED FIRERING WITH TIP-BACK ANCHORS -SHOWN WITH OPTIONAL UTILITY SHELF**

DATE 9-22-08

DWG. NO. **AI-1462**