



*Model FS-26/7/TB/S Campfire Ring
with Optional Utility Shelf*

- **Ideal for smaller fires, helps conserve firewood, and takes up less space at the campsite**
- **Flanged firering for strength and safety**
- **Single level, hinged cooking grate**
- **Structurally reinforced grate is virtually indestructible**
- **Grate tips back for fire building**
- **Public use-type spring grips of coiled steel bar**
- **Firering tips back for easy cleaning**
- **Tip-back anchors embedded in concrete footings provide permanent location**
- **“Bottomless” design installs without concrete pad**
- **Utility shelf option**
- **Quality construction throughout**

SPECIFICATIONS:

- **Model FS-26/7/TB** is a 26" overall dia. ring with a 7-3/8" high fire barrier formed from 3/16" steel with a 1" formed (NOT WELDED) flange around the top of the ring and 9/16" draft holes spaced around the bottom perimeter.
- 290 sq. in. grate is constructed from 5/8" dia. A-36 steel bars around the perimeter, 3/4" dia. A-36 steel bar for the handle and 1/2" dia. A-36 steel bars to provide the grate surface.
- Grate is attached to and hinge upon 2 tightly formed eyelets made from 5/8" dia. A-36 steel bar that makes a mechanically secure theft-proof attachment.
- Grate tips over backward to allow unobstructed viewing of the fire by persons seated around the fire. Grate is supported by the ground when tipped back so grate cannot be vandalized.
- Grate handle is provided with two substantially constructed spring grips suitable for public use made from 1/8" x 1/2" steel flat bar.
- Ring is provided with hinged anchoring device to allow ring to tip upward for easy cleaning. Two 1/2" dia. steel "U" anchor pins with deformed ends insert 15" into concrete footing (indicated by /TB in model no., e.g. FS-26/7/TB).
- Entire unit is finished in high temperature, heat resistant, nontoxic black enamel.
- **Optional:** Firering is provided with a 3/16" x 7-1/8" x 9-5/8" steel plate utility shelf. (Add /S to model no., e.g. FS-26/7/TB/S)

AVAILABLE OPTIONS

Utility Shelf

RJThomas Mfg. Co., Inc.

PO Box 946 • Cherokee, IA 51012-0946 • PH: 712-225-5115 • 800-762-5002 • FAX: 712-225-5796
E-mail: pilotrock@rjthomas.com • Web Site: <http://www.pilotrock.com>

© 2008 RJThomas Mfg. Co., Inc. PILOT ROCK® Park Products is a registered trademark of RJThomas Mfg. Co., Inc.

26 NOM
DIA

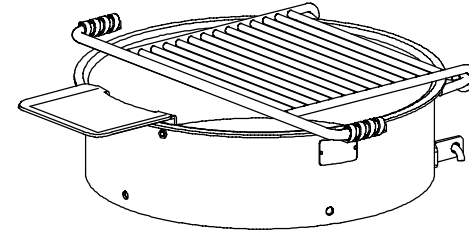
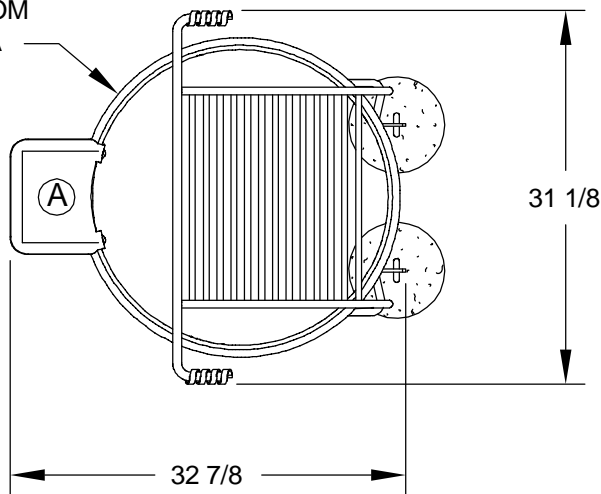

(A) OPTIONAL UTILITY SHELF - ADD /S
TO MODEL NUMBER

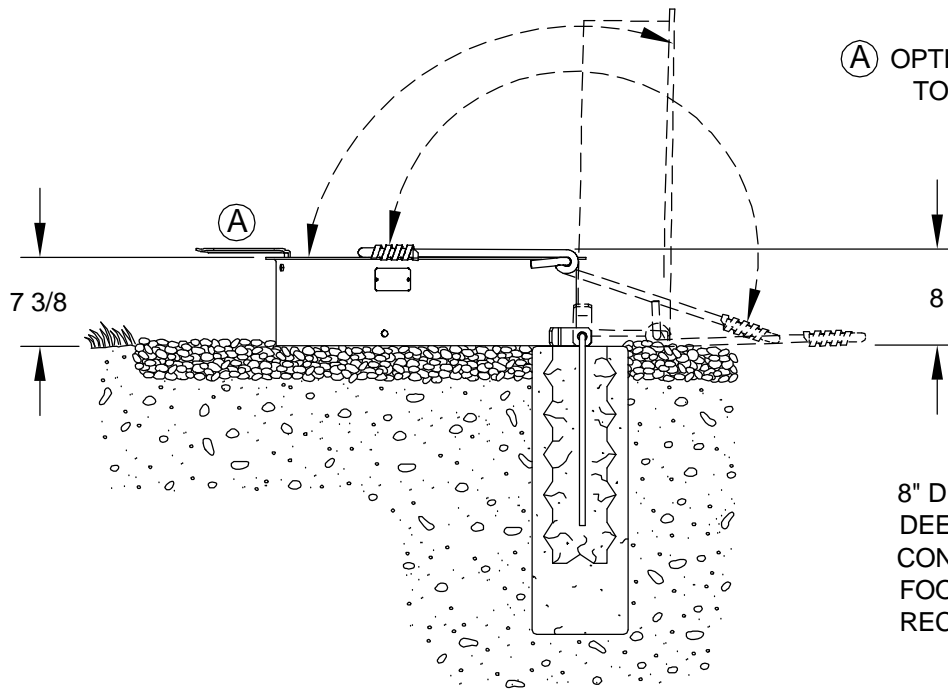

8" DIA x 24"
DEEP (18" MIN)
CONCRETE
FOOTING
RECOMMENDED

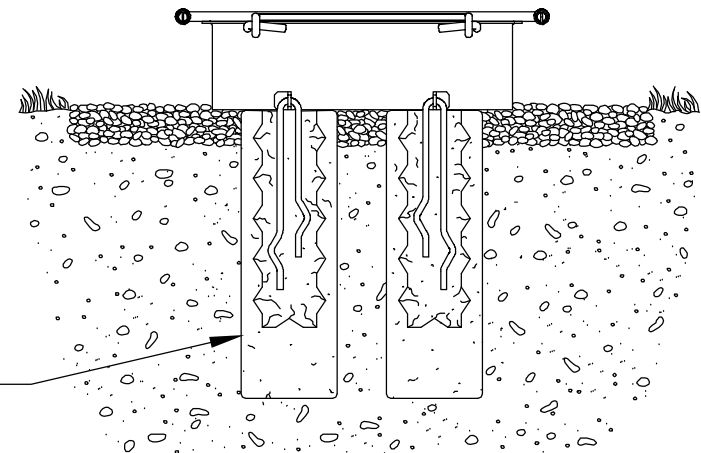

ALL DIMENSIONS IN INCHES

RJThomas Mfg. Co., Inc.
P.O. Box 946 • Cherokee, IA 51012-0946

DRAWN BY
WWM

TITLE FS-26/7/TB CAMPFIRE RING WITH TIP-BACK ANCHORS
-SHOWN WITH OPTIONAL UTILITY SHELF

DATE 9-16-08

DWG. NO. AI-1455