



**Model FSW-26/18/PA/H** Wheelchair Accessible  
Campfire Ring with swivel cooking grate.  
Shown with optional heat shield.

(Below) Grate shown rotated out of the firering.



- **Meets ADA guidelines, requires less than five pounds of force with one hand to move grate out of firering**
- **Handle is never over the fire**
- **Flanged firering for strength and safety**
- **Public use-type spring grips of coiled steel bar**
- **Elevated cooking grate and firebed conform to ADA guidelines**
- **Required aggregate fill protects site surfaces such as paver blocks, cement, and asphalt from heat damage**
- **Quality construction throughout**

## AVAILABLE OPTIONS

Utility Shelf  
Heat Shield

## SPECIFICATIONS:

- **FSW Series** firering is designed to meet ADA guidelines requiring less than five pounds of force with one hand to operate the grate.
  - 27" overall dia. firering is constructed from 3/16" thick steel with a formed (NOT WELDED) 1" flanged lip around the top of the ring and ten 1" dia. drain/draft/anchor holes located around the perimeter.
  - **Model FSW-26/18/PA** firering side height is 17-1/8".
  - The single level, 238 sq. in. cooking grate is constructed from 1/2" dia. A-36 steel bars around the perimeter, 5/8" dia. A-36 steel bar for the handle, and 3/8" dia. A-36 steel bar for the grate bars.
  - Grate is provided with a substantially constructed spring grip suitable for public use made from 1/8" x 1/2" flat bar (not wire springs).
  - Grate is mounted on a 2-3/8" OD tube allowing it to rotate on a horizontal plane out of the firering. Two welded-on stops limit rotation to 180° to prevent the handle entering the area over the fire.
  - Firering is designed to be filled with customer supplied aggregate fill to a minimum of 9" above ground level to conform with ADA guidelines to raise fire to proper height. Fill also protects hard surfaces from heat damage.
  - Unit is provided with three 1/2" dia. anchor pins for concrete embedment (indicated by "/PA" in model no., e.g. FSW-26/18/PA).
  - Entire unit is finished in high temperature, heat resistant, nontoxic black enamel paint.
  - **Optional:** Firering is provided with a 3/16" x 7-1/8" x 9-5/8" steel plate utility shelf. (Add "/S" to model no., e.g. FSW-26/18/PA/S.)
  - **Optional:** Firering is provided with a 34" overall dia. x 8" high heat shield constructed from 10 ga. steel with an inwardly formed 3/16" flanged lip and is mounted to the firering with three bolt-on brackets. Heat shield provides a 1-1/4" cooling air gap around the area of the firering exposed to the fire (indicated by "/H" in model no., e.g. FSW-26/18/PA/H).
- Note: The optional utility shelf fits both firering and optional heat shield. (When ordering both options, add "/H/S" to model no., e.g. FSW-26/18/PA/H/S.)

**RJThomas Mfg. Co., Inc.**

PO Box 946 • Cherokee, IA 51012-0946 • PH: 712-225-5115 • 800-762-5002 • FAX: 712-225-5796  
E-mail: pilotrock@rjthomas.com • Web Site: <http://www.pilotrock.com>

© 2008 RJThomas Mfg. Co., Inc. PILOT ROCK® Park Products is a registered trademark of RJThomas Mfg. Co., Inc.

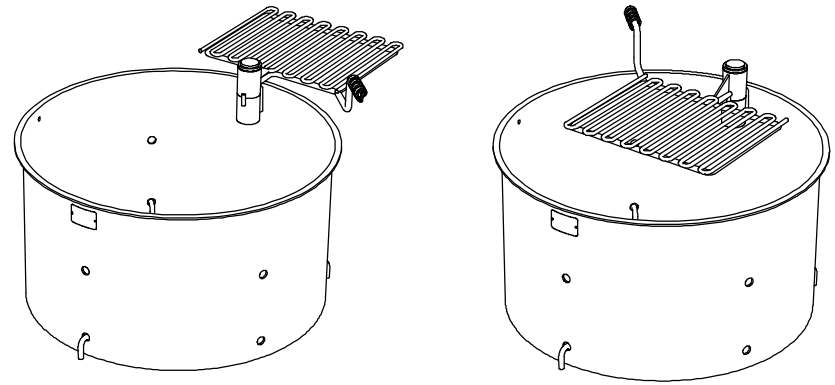
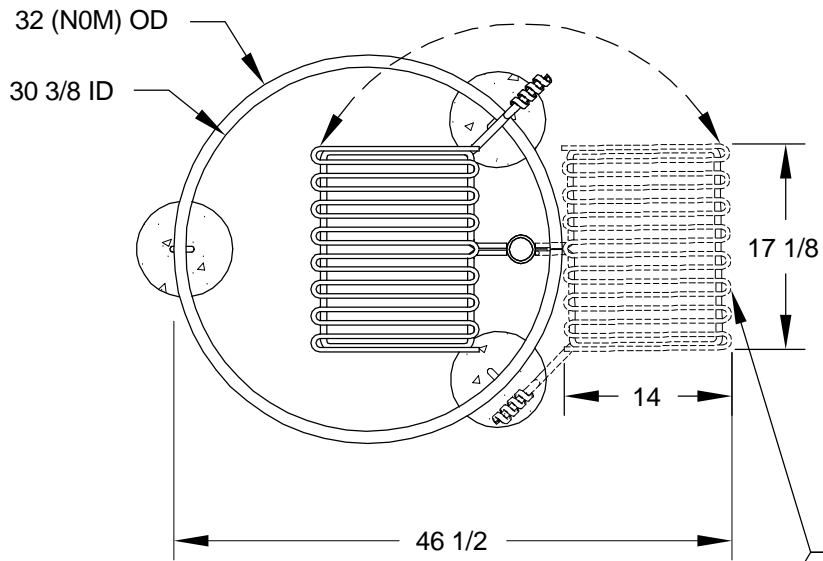

GRATE ROTATES 180 DEGREES  
TO OUTSIDE FIRERING

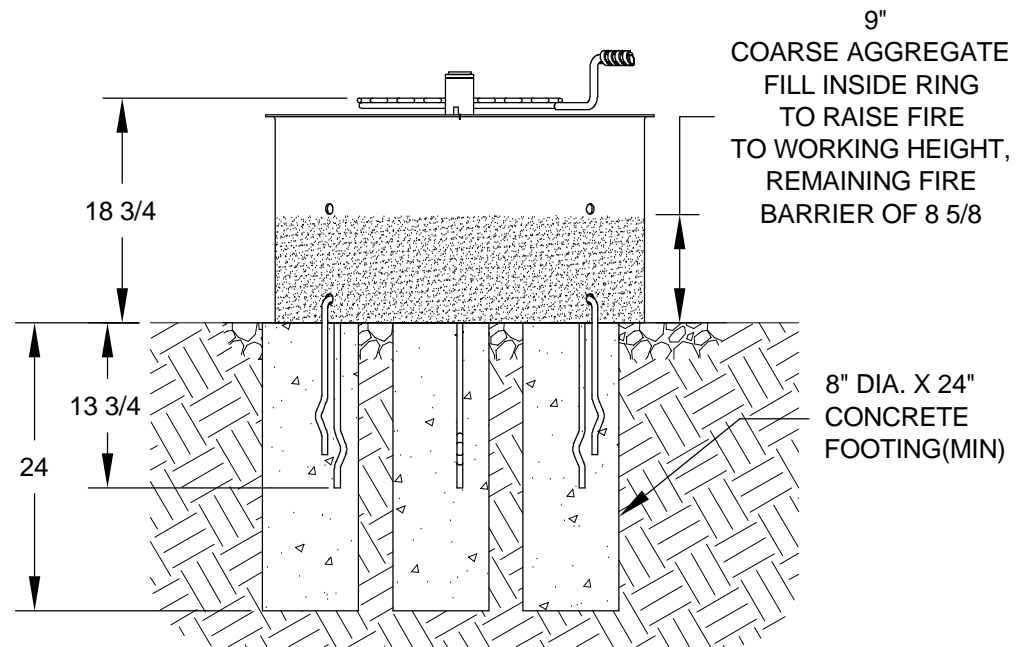
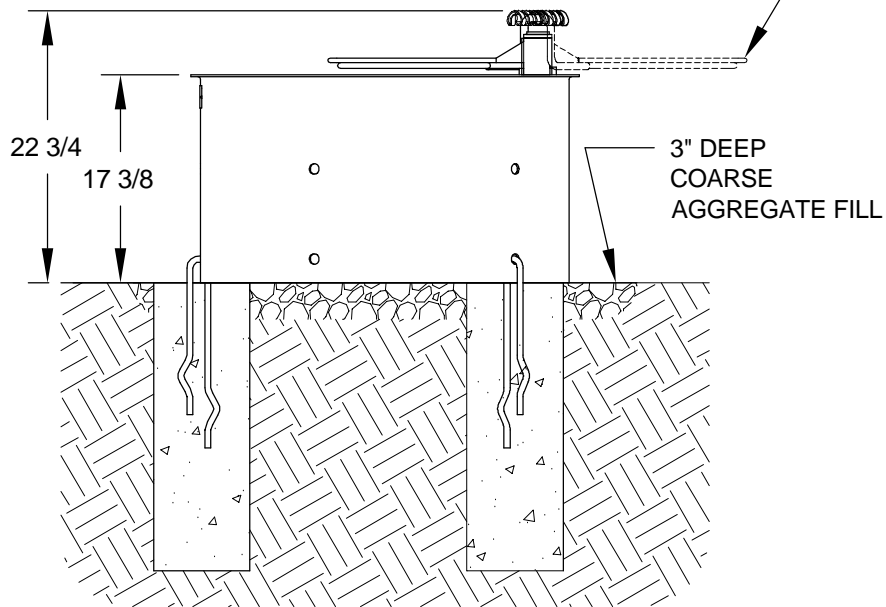

ALL DIMENSIONS IN INCHES

**RJThomas Mfg. Co., Inc.**  
P.O. Box 946 • Cherokee, IA 51012-0946

DRAWN BY  
**WWM**

TITLE FSW SERIES MODEL FSW-30/18/PA ACCESSIBLE FIRERING WITH PIN ANCHORS

DATE 3-02-09

DWG. NO. AI-1862